

Pamphlet 155

*Water and Wastewater
Operators Chlorine
Handbook*

Edition 2



Table of Contents

1.	INTRODUCTION.....	1
1.1	Scope	1
1.2	Chlorine Institute Stewardship Program	1
1.3	Abbreviations and Acronyms.....	1
1.4	Disclaimer.....	2
1.5	Approval	3
1.6	Revisions.....	3
1.7	Reproduction	3
2.	GENERAL INFORMATION FOR WATER AND WASTEWATER TREATMENT.....	3
2.1	Usage	3
2.2	Physical and Chemical Properties.....	3
2.3	Special Concerns for Operators	5
3.	CHLORINE CONTAINERS.....	7
3.1	General.....	7
3.2	Cylinders	8
3.3	Ton Containers.....	9
3.4	Cargo Tanks (Trailers)	11
3.5	Tank Cars (Rail)	11
3.6	Stationary Storage Tanks.....	11
4.	TRANSPORTATION, STORAGE, AND HANDLING OF CONTAINERS.....	12
4.1	Transportation of Chlorine	12
4.2	Receiving and Unloading Chlorine Containers.....	12
4.3	Leak Detection and Correction.....	13
4.4	General Storage Considerations	15
5.	PIPING/FEED SYSTEMS	16
5.1	Basic Systems	16
5.2	Piping Systems for Dry Chlorine.....	17
5.3	Vacuum Systems.....	21
5.4	Vaporizers (Evaporators)	21
5.5	Testing Chlorine Feed Systems	21
5.6	Manifolding Cylinders and Ton Containers	21
5.7	Automatic Container Shut-Off.....	21
5.8	Role of the Chlorine Supplier	21
6.	CONNECTING AND UNLOADING TO THE SYSTEM.....	22
6.1	Types of Connections.....	22
6.2	Vapor Pressure/Temperature Relationship	25
6.3	Unloading/Feed Rates.....	25

7.	BUILDING/STRUCTURE CONCERNS	26
7.1	Design and Construction	26
7.2	Electrical Systems	26
7.3	Ventilation and Air Openings	26
7.4	Heating	27
7.5	Absorption and Automatic Shut-Off Systems	27
7.6	Sprinkler Systems	27
7.7	Exits and Windows	27
7.8	Gas Detection.....	28
8.	SECURITY	28
9.	EMPLOYEE TRAINING, SAFETY, AND PERSONAL PROTECTION EQUIPMENT	28
9.1	Plant Employee Training	28
9.2	Personal Protection Equipment and Safety.....	31
9.3	Other Safety Equipment	34
10.	HANDLING EMERGENCIES.....	34
10.1	Planning	34
10.2	Establishing Procedures.....	35
10.3	Training	35
10.4	Audits and Exercises	37
11.	MEDICAL ASPECTS.....	38
11.1	Hazards to Health.....	38
11.2	Acute Toxicity	39
11.3	Chronic Toxicity	39
11.4	CI Health Video	39
12.	FIRST AID.....	40
12.1	Inhalation.....	40
12.2	Contact with Skin.....	42
12.3	Contact with The Eyes	42
13.	REFERENCES.....	43
13.1	CI Publications	43
13.2	Directory of Organizations	45
	APPENDIX A - SARA TITLE III REPORTING REQUIREMENTS.....	46
	APPENDIX B - OCCUPATIONAL SAFETY AND HEALTH ADMIN. REGULATION	47
	APPENDIX C - PROCESS SAFETY MANAGEMENT	49
	APPENDIX D - RISK MANAGEMENT PROGRAM.....	50

1. INTRODUCTION

1.1 SCOPE

Chlorine is the most widely used disinfectant in water and wastewater treatment plants in the world. Although sodium and calcium hypochlorites are also used in water and wastewater treatment, this document deals only with elemental chlorine.

This manual is intended to provide basic information on chlorine safety for treatment plant personnel. Throughout this text, the reader is referred to other Chlorine Institute (CI) publications for technical topics requiring detailed explanations of the subject matter or for subjects of specific interest.

1.2 CHLORINE INSTITUTE STEWARDSHIP PROGRAM

The Chlorine Institute, Inc. (CI) exists to support the chlor-alkali industry and serve the public by fostering continuous improvements to safety and the protection of human health and the environment connected with the production, distribution and use of chlorine, sodium and potassium hydroxides, and sodium hypochlorite; and the distribution and use of hydrogen chloride. This support extends to giving continued attention to the security of chlorine handling operations.

Chlorine Institute members are committed to adopting CI safety and stewardship initiatives, including pamphlets, checklists, and incident sharing, that will assist members in achieving measurable improvement. For more information on the Institute's stewardship program, visit the CI website at www.chlorineinstitute.org.

1.3 ABBREVIATIONS AND ACRONYMS

ACC	American Chemistry Council
ACGIH	American Conference of Governmental and Industrial Hygienists
AIHA	American Industrial Hygiene Association
ASTM	American Society for Testing and Materials; now known solely by the acronym
AWWA	American Water Works Association
CAS	Chemical Abstracts Service
CHEMTREC	Chemical Transportation Emergency Center
CFR	Code of Federal Regulations
CGA	Compressed Gas Association
CHLOREP	Chlorine Emergency Plan – Activated Through CHEMTREC
CI	The Chlorine Institute, Inc.
CIIT	Chemical Industry Institute of Technology
DOT	Department of Transportation
EPA	U.S. Environmental Protection Agency

EPCRA	Emergency Planning and Community Right-to-Know Act
ERP	Emergency response plan
ERPG	Emergency response planning guidelines
HAZMAT	Hazardous materials
ICC	International Code Council
IDLH	Immediately dangerous to life and health
LEPC	Local emergency planning committee
MSDS	Material safety data sheet
NFPA	National Fire Protection Association
NIOSH	National Institute of Occupational Safety and Health
OSHA	Occupational Safety and Health Administration
PEL	Permissible exposure limits
PPE	Personal protective equipment
PSM	Process safety management
RMP	Risk management plan
RMPR	Risk Management Program Rule
SARA	Superfund Amendments and Reauthorization Act of 1986
SCBA	Self-contained breathing apparatus
STEL	Short-term exposure limits
TLV	Threshold limit value
TWA	Time-weighted average
WEF	Water Environment Federation

1.4 DISCLAIMER

The information in this pamphlet is drawn from sources believed to be reliable. The Institute and its members, jointly and severally, make no guarantee, and assume no liability, in connection with any of this information. Moreover, it should not be assumed that every acceptable procedure is included, or that special circumstances may not warrant modified or additional procedures. The user should be aware that changing technology or regulations may require changes in the recommendations contained herein. Appropriate steps should be taken to ensure that the information is current, when used. These recommendations should not be confused with federal, state, provincial, municipal, or insurance requirements, or with national safety codes.

1.5 APPROVAL

The Institute's Customer Stewardship Issue Team approved Edition 2 of this pamphlet on January 3, 2008.

1.6 REVISIONS

Suggestions for revisions should be directed to the Secretary of the Institute.

1.7 REPRODUCTION

The contents of this pamphlet are not to be copied for publication, in whole or in part, without prior Institute permission.

2. **GENERAL INFORMATION FOR WATER AND WASTEWATER TREATMENT**

2.1 USAGE

Chlorine's primary use in potable water treatment is as a disinfectant to destroy harmful organisms. It can also remove color and ammonia compounds, eliminate hydrogen sulfide, oxidize iron and manganese to insoluble forms, and reduce undesirable taste and odors.

Chlorine's primary use in wastewater treatment is to disinfect the effluent to protect the receiving waters. Other wastewater uses include the destruction of hydrogen sulfide, control of odors, removal of ammonia and ammonia compounds, control of filamentous biomass, oxidation of organics, and control of filter flies.

2.2 PHYSICAL AND CHEMICAL PROPERTIES

The chemical symbol for elemental chlorine is Cl. Chlorine exists as a molecule containing two atoms, shown chemically as Cl₂. Chlorine has an atomic weight of 35.453, a molecular weight of 70.906, and an atomic number of 17. Some of the physical properties of chlorine are given in Table 1. While it is not explosive or flammable, as a liquid or gas it can react violently with many substances. Chlorine is only slightly soluble in water (0.3 to 0.7% by weight.)

Chlorine gas has a greenish-yellow color. It has a characteristic disagreeable and pungent odor, similar to chlorine-based laundry bleaches, and is detectable by smell at concentrations as low as 0.2 to 0.4 ppm. It is about two and a half times as heavy as air. Consequently, if chlorine gas escapes from a container or system, it will seek the lowest level in the building or area.

Liquid chlorine is amber in color and is about one and a half times as heavy as water. Chlorine is seldom seen as a liquid because it boils (converts to a gas) at about -29°F (-34°C) at atmospheric pressure.

The term dry chlorine does not refer to dry chlorinating chemicals such as calcium hypochlorite. It refers to liquid or gaseous elemental chlorine with a very low water content (see Cl Pamphlet 100). While dry chlorine reacts violently with some metals, it is not corrosive to metals such as copper or carbon steel. However, wet chlorine is highly corrosive to most metals (Section 2.3.5). Chlorine shipped in rail cars, cargo tanks, cylinders, and ton containers is dry chlorine.

Problems attributable to wet chlorine are usually due to moisture in a system and can result from poor operating practices at the water or wastewater plant.

Table 1. Physical Properties of Chlorine

Boiling point (liquefying point) at 1 atmosphere = 14.696 psi (101.325 kPa)	-29.15°F (-33.97°C)
Melting point (freezing point) at 1 atmosphere	-149.76°F (-100.98°C)
Liquid density at 60°F (16°C)	88.76 lb/cu ft (1,422 kg/m ³)
Gas density at 34°F (1.1°C)	0.2006 lb/cu ft (3.213 kg/m ³)
Specific gravity (liquid) at 32°F (0°C)	1.468 (water = 1)
Specific gravity (gas) at 32°F (0°C)	2.485 (air = 1)
Water solubility at 70°F (21.1°C)	0.7% by weight
Vapor pressures:	
at 32°F (0°C)	53.51 psi (368.9 kPa)
at 77°F (25°C)	112.95 psi (778.8 kPa)
at 129°F (48.9°C)	191.01 psi (1,316.8kPa)

Chlorine gas reacts with water to form both hypochlorous and hydrochloric acids (Eq. 1):

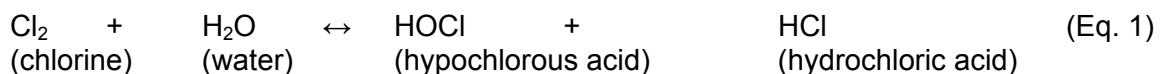

Hypochlorous acid dissociates in water to form the hydrogen and hypochlorite ions (Eq. 2):

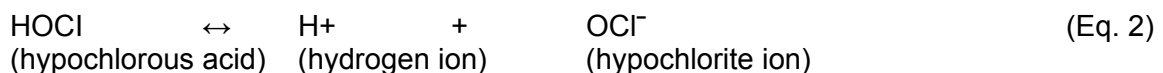

The degree of dissociation is dependent on the pH and temperature of the water.

Hypochlorous acid is the dominant form of chlorine in water up to pH 7.8. A significant percentage of the chlorine is still in the form of hypochlorous acid even between pH 8 and pH 9 (Table 2). Each plant must determine the dose and residual needed to achieve disinfection. Hypochlorous acid is the predominant form of chlorine for disinfection.

Table 2. Percent Hypochlorous Acid and Hypochlorite Ion at 68°F

pH	%HOCL	%OCL ⁻
5.0	99.7	0.3
5.5	99.2	0.8
6.0	97.5	2.5
6.5	92.4	7.6
7.0	79.3	20.7
7.5	54.8	45.2
8.0	27.7	72.3
8.5	10.8	89.2
9.0	3.7	96.3
9.5	1.2	98.8
10.0	0.4	99.6
10.5	0.1	99.9

2.3 SPECIAL CONCERNS FOR OPERATORS

2.3.1 Liquid-Gas Volume Relationship

One volume of liquid chlorine yields about 460 volumes of chlorine gas. For example, 1 pound or about 11 fluid ounces of liquid chlorine yields approximately 5.4 cubic feet of 100% chlorine gas when vaporized at normal temperature [70°F (21.1°C)] and atmospheric pressure. Therefore, one 150-lb cylinder would completely fill a 10 x 10 x 8-foot room with 100% chlorine gas.

2.3.2 Liquid-Gas Temperature Effect

The vaporization of liquid chlorine on skin or clothing may reduce the temperature enough to cause frostbite (even through high-quality protective clothing), cause the fogging of protective face masks, or the freezing of footwear to the ground. It is essential to wear the proper PPE during all routine operations.

2.3.3 Physiological Effects of Chlorine Exposure

Chlorine is an irritant to the eyes, skin, mucous membranes, and the respiratory system. The primary concern with exposure to chlorine is the respiratory system followed by the eyes. The impact of exposure to chlorine is both concentration and time dependent. People with respiratory conditions should inform their doctor that they work around chlorine. Extra precautions may be necessary. Table 3 summarizes exposure levels and effects on humans.

Table 3. Chlorine Exposure Levels and Effects on Humans

Exposure levels (ppm)	Effects
0.2 to 0.4	Odor threshold (varies by individual)
less than 0.5	No known acute or chronic effect
0.5	ACGIH 8-hour time weighted average
1.0	OSHA ceiling level (PEL) TLV-STEL ERPG-1
1 to 10	Irritation of the eyes and mucous membranes of the upper respiratory tract. Severity of symptoms depends on concentrations and length of exposure.
3	ERPG-2 (Emergency Response Planning Guidelines as values developed by AIHA) is the maximum airborne concentration below which it is believed that nearly all individuals could be exposed for up to 1 hour without experiencing or developing irreversible or other serious health effects that could impair an individual's ability to take protective action
10	NIOSH IDLH (immediately dangerous to life and health)
20	ERPG-3 is the maximum airborne concentration below which it is believed that nearly all individuals could be exposed for up to one hour without experiencing or developing life-threatening health effects.

As the duration of exposure or the concentration increases, the affected individual may become apprehensive and restless, with coughing accompanied by throat irritation, sneezing, and excess salivation. At higher levels, vomiting associated with labored breathing can occur. In extreme cases, difficulty in breathing can progress to the point of death through suffocation. An exposed person with a preexisting medical or cardiovascular condition can have an exaggerated response. **Anyone exhibiting these symptoms should see a qualified healthcare provider immediately as his or her condition is likely to deteriorate over the next few hours.**

2.3.4 Reaction with Water

Chlorine is only slightly soluble in water, in which it forms a weak solution of hydrochloric and hypochlorous acids (Eq. 1). Chlorine hydrate, a greenish ice-like substance ($\text{Cl}_2 \cdot 8\text{H}_2\text{O}$), may form as crystals below 49.3°F (9.6°C) at atmospheric pressure.

Chlorine hydrate can also form at higher temperatures if the chlorine is at an increased pressure. These crystals can interfere with the proper operation of chlorination systems.

Reactions with Metals

Below 250°F (121°C) iron, copper, steel, lead, nickel, platinum, silver, and tantalum are resistant to dry chlorine (gas or liquid state). At ordinary temperatures dry chlorine reacts (often violently) with aluminum, arsenic, gold, mercury, selenium, tellurium, tin, and titanium. Carbon steel ignites at 483°F (251°C) in a chlorine atmosphere (See CI Pamphlet 164).

Wet chlorine forms acids and is very corrosive to most common metals. Platinum, silver, and tantalum are resistant to both wet and dry chlorine. Titanium is unique because it is resistant to wet chlorine but cannot be used in contact with dry chlorine. Experts should be consulted when dealing with systems using wet chlorine.

2.3.5 Other Reactions

Chlorine should be segregated from ammonia and ammonia compounds because potentially violent reactions could result in the event of a chlorine release.

Chlorine reacts with many organic compounds. Some of these reactions can be violent or explosive, including those with oils, greases, solvents, coolants, and other hydrocarbons. The separation of these materials during storage and use is essential to safety. This is especially important when new components including piping are added to the chlorine system. Even thin layers of oils and greases can react violently (See CI Pamphlets 6 and 164).

3. CHLORINE CONTAINERS

3.1 GENERAL

Chlorine is shipped and stored in pressure vessels as a liquefied gas under pressure. While on-site stationary tanks are used solely for storage, chlorine is commonly transported in cylinders, ton containers, cargo tanks, and rail tank cars. Cylinders and ton containers have many handling similarities, but different equipment is needed to deal with emergencies involving each type of container. Chlorine Institute Emergency Kit and cylinder recovery vessels are designed to contain most container leaks. These include:

- Kit A: for 100- and 150-lb cylinders
- Kit B: for ton containers
- Kit C: for tank cars and cargo tanks (tank trucks), and
Cylinder Containment Vessels for 100 and 150-lb cylinders

Confusion can be avoided if the term "ton containers" is used and *not* "ton cylinders".

Chlorine ton containers and cylinders must always be handled with care and should not be dropped or struck. During transport, containers must be secured to prevent them from moving. A loading dock or a hydraulic tailgate on the truck should be used when unloading. A container valve's protective housing and valve outlet cap should be in place when the container is not in use.

3.2 CYLINDERS

Chlorine cylinders may include foot-ring, bumped-bottom, and double-bottom construction (Figure 1), with only one opening permitted. The most common sizes are 100 lb (45 kg) and 150 lb (68 kg). Table 4 lists tare weights [the weight of an empty container with valves and fusible plugs (safety relief devices) but without valve protection devices] and dimensions of 100-lb and 150-lb cylinders. The CI has developed recommended criteria for cylinder valves. This can be found in an appendix to CI Pamphlet 17. The valve outlet threads are *not* standard pipe threads.

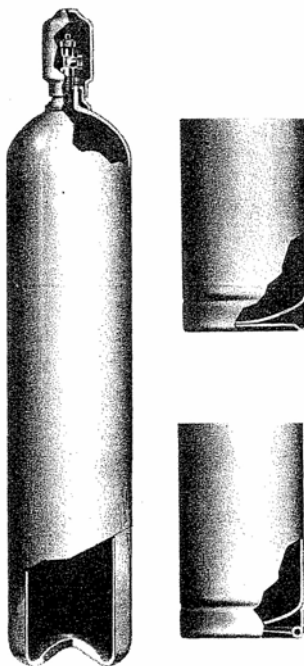

Figure 1 - Chlorine Cylinder
(Left - bump-bottom; Upper right - double-bottom; Lower right - foot-ring)

Cylinder valves are equipped with a pressure relief device consisting of a fusible metal plug in the valve body, located below the valve seat. The fusible metal is designed to melt between 158°F and 165°F (70°C and 74°C) to relieve pressure and prevent rupture of the cylinder in case of exposure to high temperatures.

Cylinders should always be stored upright. They are stamped near the neck ring area with the tare weight and the date of the last hydrostatic test. According to U.S. Department of Transportation [DOT] or Canadian Transportation of Dangerous Goods Regulations, cylinders must be hydrostatically tested every five years. DOT regulations prohibit the marring or defacing of these markings. Cylinders must be designed for use with CI Chlorine Emergency Kit A for Cylinders.

Table 4. Container Dimensions and Weights

Capacity		100 lb (45 kg)	150 lb (68 kg)	2,000 lb (907 kg)
Volume of liquid chlorine (approximate at 60°F/15.6°C)	(gal) (L)	8.42 31.87	12.64 47.85	168.5 637.8
Tare weight	(lb) (kg)	63-115 29-52	85-140 39-64	1,300-1,650 590-748
Outside diameter	(in) (mm)	8.25-10.75 210-273	10.25-10.75 260-273	30 762
Cylinder Height	(in) (mm)	39.5-59* 1,003-1,499*	53-56* 1,346-1,422*	
Ton Container Length	(in) (mm)			79.75-82.5 2,026-2,096

*Heights are to the top of the valve protection housing. The height to the center of the valve outlet is about 3.5 in. (89 mm) less.

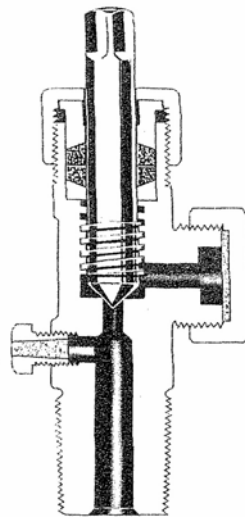

Figure 2 - One Typical Style of a Cylinder Valve (Other Designs May Also be in Use)

3.3 TON CONTAINERS

Ton containers (Figure 3) are welded steel tanks with a chlorine capacity of 2,000 lb (907 kg) and a loaded weight of as much as 3,650 lb (1,659 kg). They are stamped with a serial number, the tare weight, and the date of the most recent hydrostatic test. Refer to Table 4 for dimensions and weights.

The heads are either concave or convex and welded to the barrels. The chimes (the steel wall that extends beyond each head) provide a substantial grip for lifting beams. The container valves are protected by a removable steel valve protective housing. Ton containers have two valves and can supply either liquid or gas. When the valves are properly aligned in a vertical position, the upper valve feeds chlorine gas while the lower valve feeds liquid chlorine. The container has three fusible plugs in each end that are designed to melt between 158°F and 165°F (70°C and 74°C) to relieve internal pressure.

The CI has developed recommended criteria for ton container valves. This can be found in an appendix to CI Pamphlet 17. The valve outlet threads are not standard pipe threads. All ton containers must be able to accommodate the use of the devices in CI Emergency Kit B.

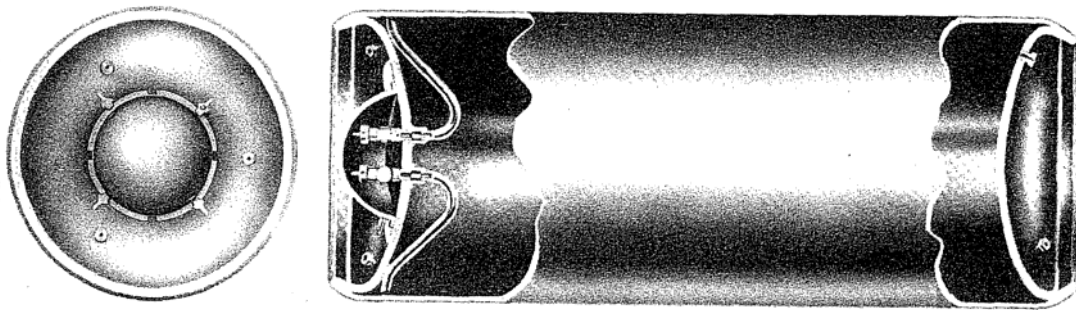

Figure 3 - Chlorine Ton Container

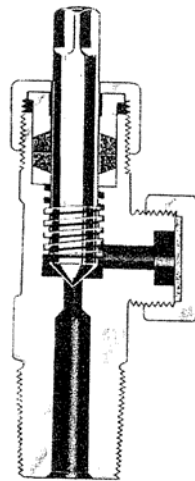

Figure 4 - One Style of a Chlorine Ton Container Valve (Other Designs May Also be in Use)

3.4 CARGO TANKS (TRAILERS)

Cargo tanks are used to transport chlorine over roads and highways. They have a capacity of 15-22 tons (13,600 kg-20,000 kg.) Cargo tanks use the same man way and valve arrangements as rail tank cars (Section 3.5) and are required to have excess flow check valves under both the liquid and gas angle valves (CI Pamphlet 49).

All chlorine cargo tanks have four angle valves. They also have one safety relief valve designed to release excess pressure buildup within the tank. They are designed to relieve pressure at 225 psi (1,551 kPA.) Two of the angle valves are located on the longitudinal center of the tank. These valves are connected to eduction pipes that run to the bottom of the tank and are used to unload liquid chlorine. Two angle valves are located on a line perpendicular to the tank's length and are connected to the vapor phase. These valves should never be used for gas withdrawal, but can be used to pressurize the car when needed to increase the rate of liquid withdrawal. All four valves are equipped with excess flow valves designed to close at a flow rate of 7,000 lb/hr (3,200 kg/hr).

CI Emergency Kit C is designed for stopping leaks on chlorine cargo tanks and tank cars (CI Pamphlet 49).

3.5 TANK CARS (RAIL)

Tank cars for transporting chlorine via railroad have capacities of 55, 85, or 90 tons, and they may not be loaded in excess of these nominal loading weights. The only opening into tank cars is through a manway on top, where the valves are enclosed with a steel cover.

All chlorine tank cars have four angle valves. They also have one safety relief valve designed to release excess pressure buildup within the tank. Two of the angle valves are located on the longitudinal center of the car. These valves are connected to eduction pipes that run to the bottom of the tank and are used to unload liquid chlorine. Two angle valves are located on a line perpendicular to the car's length and are connected to the vapor phase. These valves should never be used for gas withdrawal, but can be used to pressurize the car when needed to increase the rate of liquid withdrawal. The liquid valves are equipped with excess flow valves designed to close at flow rates of 7,000, 15,000 or 32,000 lb per hour. The flow rate is usually stenciled on the side of the car. Unstenciled cars have 7,000-lb-per-hour valves.

CI Emergency Kit C is designed for stopping leaks on chlorine tank cars and cargo tanks. For additional recommendations, see CI Pamphlet 66.

For additional guidelines, recommended practices, and other useful information concerning chlorine tank cars, refer to CI Pamphlets 1, 4, 24 and 66.

3.6 STATIONARY STORAGE TANKS

Stationary chlorine storage tanks may be found at large capacity treatment facilities. Such tanks should be designed in accordance with CI Pamphlet 5, which includes a standard tank car dome assembly (Section 3.5). Local codes should also be consulted.

4. TRANSPORTATION, STORAGE, AND HANDLING OF CONTAINERS

4.1 TRANSPORTATION OF CHLORINE

The U.S. DOT regulates the transportation of hazardous materials, including chlorine. Applicable DOT regulations appear in Title 49 of the *Code of Federal Regulations (49 CFR)*, and requires special HazMat and safety permits as of January 1, 2005. In most circumstances it is preferable to let the chlorine supplier transport the chlorine to each use site. If this arrangement is not possible, CI Pamphlet 76 contains recommendations on how to safely transport packaged chlorine. Placards are required for the transportation of any amount of chlorine. Proper labeling of the container is essential and the correct shipping papers must be on the vehicle. These requirements, including the correct wording of the paperwork and labeling, change frequently (Contact the supplier and review 49 CFR to remain current).

In Canada, you must follow the requirements of the Transportation of Dangerous Goods Regulations by Transport Canada, covering High Consequence Dangerous Goods.

The DOT and CTDG have specific training requirements for all personnel involved in the transportation of hazardous materials, from those preparing the paperwork to those loading and driving the truck (See CI Pamphlet 76).

4.2 RECEIVING AND UNLOADING CHLORINE CONTAINERS

4.2.1 Cylinders

Individual cylinders should be chained or clamped to a hand truck or otherwise secured to the moving device for unloading or relocating. If secured in a storage rack, a forklift can be used. Cylinders should not be lifted by the valve protective housing, which is not designed to carry the weight of the cylinder. The cylinders should always be secured to prevent them from falling (See CI Pamphlet 76).

4.2.2 Ton Containers

Ton containers may be lifted by using a hoist of sufficient capacity for the load in conjunction with a ton container lifting beam (Figure 5). A forklift of sufficient capacity can also be used. Whether full or empty, ton containers must always be secured to prevent them from rolling. **Warning:** An empty ton container may weigh as much as 1,650 lb and can cause severe injury if not secured (See CI Pamphlet 76).

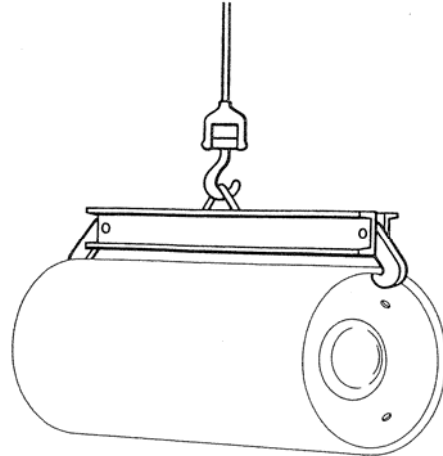

Figure 5 - Lifting Beam For Handling Chlorine Ton Containers

4.2.3 Cargo Tanks

The chlorine in cargo tanks can either be unloaded into a permanent storage tank or fed directly into the process. The storage tank must be on a scale or load cell to make certain that it can accommodate the entire shipment. A trained driver or operator should make the connections and monitor the unloading process (See CI Pamphlets 5, 49, and 57).

4.2.4 Tank Cars (Rail)

Tank cars should be inspected to make certain they are properly placarded and stenciled with UN 1017. The tank car number and arrival dates should be noted in records kept at the receiving facility. Cars should be used in the order received. They should not be connected to a system until unloading time.

Specific DOT rules and CTDG Regulations must be met for placing warning signs, derails, chocks, and bumpers, as well as for monitoring the unloading. Tank car suppliers should provide the latest DOT requirements in addition to periodic training on connecting, unloading, and disconnecting chlorine cars. Extensive training is needed by employees who work with chlorine tank cars. Automatic or remotely activated valves located on both sides of the flexible hose or copper loop should be considered to allow operators to quickly shut off the flow of chlorine in case of a leak (See CI Pamphlets 57 and 66).

4.3 LEAK DETECTION AND CORRECTION

4.3.1 Cylinder and Ton Container Leaks

When a leak is suspected, it is recommended that ammonia vapors be used to find the source. When ammonia vapor is directed at a leak, a white cloud will form. To produce ammonia vapor, a plastic squeeze bottle containing commercial, 26 degree Baume or stronger, aqua ammonia (ammonium hydroxide solution) should be used. A weaker solution such as household ammonia may not be concentrated enough to detect minor leaks. If a wash bottle is used, the dip tube inside the bottle should be cut off so that squeezing the bottle directs only the vapor, and not liquid, from the nozzle. To prevent corrosion, liquid aqua ammonia should not come into contact with any metal parts.

4.3.1.1 Responding to a Leak

Before responding to any leak, review Sections 8, 9 and 10 of this document.

Self-contained breathing apparatus (SCBA) and appropriate protective suits are required (the on-site coordinator decides what level of protection is needed). If chlorine is escaping as a liquid from a cylinder or a ton container, align the tank so that the leaking side is up. In this position the chlorine will escape only as a gas, greatly minimizing the leak.

If a chlorine valve is leaking through the valve outlet, install an outlet cap with gasket and open and close the valve. Sometimes this will clean the stem seat and stop the leak. After closing the valve, remove the outlet cap and check for leaks. If the leak will not stop, put the outlet cap back on and notify the chlorine supplier.

When the packing gland is the source of the leak, first close the valve and then tighten the packing nut. If it still leaks, make sure the valve is closed and retighten the packing gland. Care must be taken when tightening the packing gland. Over tightening may bind the valve or strip the threads and it will not close or open. Testing for leakage must be repeated after every attempt to stop the leak. Fifty foot-pounds of torque on the packing nut should stop most leaks.

If the source of the leak is at the valve threads, use a crowfoot wrench from the appropriate Chlorine Emergency Kit to tighten the valve into the container. Care should be taken to avoid stripping the threads. Do not tighten the valve if its integrity is in question. Application of other suitable devices from Chlorine Institute Emergency Kits to cap leaks or use of a cylinder containment vessel may be necessary.

Regular training with an SCBA and the use of appropriate Emergency Kits or cylinder containment vessels is essential. Comply with all applicable local, state, and federal regulations relating to both training and response requirements.

4.3.2 Cargo Tanks and Tank Cars

Responding to leaks involving tank cars and cargo tanks requires more extensive training than that needed for cylinder and ton container leaks. Personnel dealing with tank car and cargo tank leaks must be highly trained and familiar with the various features of these containers as well as with CI Pamphlets 49 and 66 and the Emergency Kit C. Coverage of the specific training required is beyond the scope of this pamphlet.

CI publishes a pamphlet and a video dedicated to Emergency C Kits.

4.3.3 Piping Systems

If a leak is found in the pressurized piping system, the chlorine supply to that section of piping must be shut off, the pressure relieved, and the system purged of all chlorine before the necessary repairs are made. The system must be purged with a dry, non-reactive gas before any welding is done. Welding should comply with all applicable codes. **Never weld on or to any chlorine container** (See CI Pamphlet 6).

4.4 GENERAL STORAGE CONSIDERATIONS

Chlorine may be stored safely indoors. If stored outdoors, shading from direct sunlight in warm climates is recommended. Containers should not be stored where they can be dropped, where heavy objects can fall on them, or where vehicles can strike them. They should not be stored near elevators, heating, ventilating, or air conditioning systems because dangerous concentrations of gas may spread rapidly if a leak occurs. Easy access to containers is important in the event of a leak. Below ground storage must be avoided because chlorine vapors are heavier than air and will not readily dissipate from low areas in the event of a leak.

The chlorine storage area must be posted properly with signs in accordance with local codes and state and federal laws and regulations. Access to storage areas by unauthorized personnel should be restricted.

4.4.1 Indoor Storage and Construction

Local fire and building codes may dictate the legal requirements for buildings used to store chlorine. Consult with the local government to determine which code is in effect in the community where the plant is located and review the code. Any building that will house chlorine containers or equipment should be designed and constructed to protect all elements of the chlorine system from fire hazards. Fire-resistant construction is recommended. Chlorine containers should be segregated from flammable and oxidizing materials and from materials such as ammonia, sulfur dioxide, hydrocarbons, certain refrigerants and other materials that are reactive with chlorine. Chlorine cylinders should be segregated from other compressed or liquefied gases. However, if flammable materials are stored or processed in the same building, a fire wall that meets the applicable fire and building code standards should be in place.

4.4.2 Outdoor Storage

Local fire codes and building codes as well as intended use may dictate the legal requirements for the outside storage of chlorine. Consult with the local government to determine which code and code year are in effect in the community where the plant is located and review the code. An outdoor storage area should be clear of trash and debris so as not to present a fire hazard. In general, it is recommended that overhead shading from the sun be provided in warm climates. Containers must not be stored in standing water.

4.4.3 Gas Detection Equipment

Installations, manned or unmanned, where chlorine is stored or used should have gas detection equipment to monitor for chlorine releases. Chlorine detectors must be designed and adequately maintained to warn personnel or to signal a remote, manned location in case of a leak. Proper maintenance includes a written plan for a regular calibration of the monitoring equipment, including written documentation of periodic testing.

4.4.4 Storage with Other Chemicals

Chlorine containers should be segregated from flammable and oxidizing materials and from materials such as ammonia, sulfur dioxide, hydrocarbons, certain refrigerants and other materials that are reactive with chlorine. Chlorine cylinders should be segregated from other compressed or liquefied gases.

5. PIPING/FEED SYSTEMS

5.1 BASIC SYSTEMS

All chlorine is shipped and stored in pressure vessels as a liquefied gas under pressure, resulting in the presence of both liquid and gas phases in the containers. Cylinders are nearly always used to feed chlorine as a gas. Ton containers have two valves and can supply either liquid or gas. When the valves are properly aligned in a vertical position, the upper valve feeds chlorine gas while the lower valve feeds chlorine as a liquid (Figure 6). Cargo tanks and tank cars should only be used to feed liquid chlorine.

In water and wastewater treatment operations, the removal of gaseous chlorine from a cylinder or ton container is usually controlled by the use of a vacuum-operated, gas feed chlorinator. A chlorinator is a piece of equipment used to feed chlorine gas into water. The vacuum is produced by a water-operated venturi that mixes the chlorine with the water and produces a high-strength chlorine solution. This solution is piped and diffused into the water or wastewater to provide the required chlorine dosage.

If liquid chlorine is being withdrawn from a ton container, the liquid chlorine must be converted to a gas by passing through a vaporizer and the resulting gas is fed into the chlorination system. Chlorinators are designed to handle gaseous chlorine. Liquid chlorine may damage gas chlorinators.

There are a few major areas of concern for the operation of a gas chlorinator, including the cleanliness of the chlorine supplied and the safety of the piping system. The quality of the chlorine is important because the chlorinator feeding the gas has small orifices and fine control valves that can be clogged or plugged. The operator should make every effort to ensure that the entire chlorine delivery system is as clean as possible. A chlorinator has a filter at the inlet of the unit that requires periodic inspection and replacement to maintain system integrity. The appearance of a film on the gas metering tube is usually an indication of a problem. If the film is reddish in color, the piping system from the chlorine container to the chlorinator or the container may contain ferric chloride. This substance forms when moisture reacts with chlorine inside of a steel piping system.

The container outlet valve is supplied with a valve cap. When the valve cap is removed, plant personnel should inspect the outlet and remove any foreign material before placing it in service.

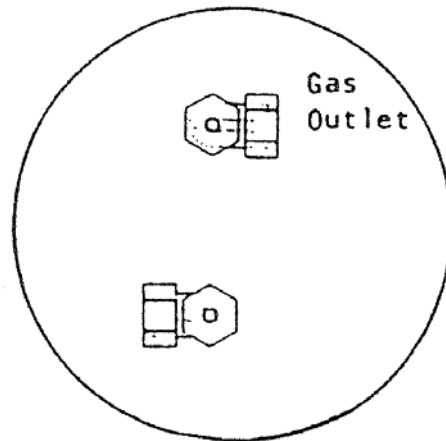

Figure 6 - Ton Container Valve Configuration

5.2 PIPING SYSTEMS FOR DRY CHLORINE

The gas chlorinator is designed to operate only with chlorine gas. Most current gas chlorinator installations mount directly on the container valve to feed gas from the container. When installed in this fashion, there is minimal chance of liquid carryover from the container to the gas chlorinator.

When chlorine containers discharge into a pressure manifold, the gas chlorinator is connected to the manifold and additional concerns arise. The pressure piping must be installed so that no liquid chlorine or chlorine liquid droplets can enter the gas chlorinator. Any liquid chlorine, including droplets, will eventually damage the chlorinator and could cause serious safety problems. The following are recommendations that will help prevent this from happening:

1. The container storage room and pressure piping manifold should be kept at a temperature that will allow the feed rates desired.
2. All gas piping under pressure must be protected from cold drafts (windows, doors, cellars, etc.) that can cause reliquification, because any liquid chlorine formed will be carried by the gas stream to the chlorinator.
3. Facilities may need to consider low-level heat tracing for gas pressure piping made of steel. This may be needed to maintain the temperature above the reliquification point (See Figure 7). Do not apply other sources of heat to chlorine lines. This procedure should be reviewed with a person trained in designing or operating chlorine systems.
4. The addition of drip legs at points of pipeline direction change may be required. The drip legs, equipped with small pad heaters, can aid in the removal of any liquid carryover.

5. Pressure reduction by the use of a pressure-reducing valve will help prevent reliquification in the pressure line. A vacuum regulator may be directly connected to a cylinder or ton container minimizing the number of pressurized connections. This will allow the system to be operated under a vacuum. When containers are manifolded to achieve a higher feed rate, the vacuum regulator or pressure reducing valve may be mounted on the end of the manifold.
6. Slope the gas pressure line downward from the feed equipment toward the chlorine container.
7. Examine the flexible copper connectors (pigtailed) periodically. If a noise is heard when the tubing is flexed there may be internal corrosion and the tubing should be replaced. Flexible connectors should be replaced at least annually.
8. Check for external corrosion of equipment (valves, piping, fittings, etc.), which may be an indication of internal corrosion.

This section provides basic information about dry chlorine liquid or gas piping systems. (See CI Pamphlet 6.)

Figure 7 - Vapor Pressure of Liquid Chlorine

Vapor Pressure of Liquid Chlorine
(Calculated from data in CI Pamphlet 72)

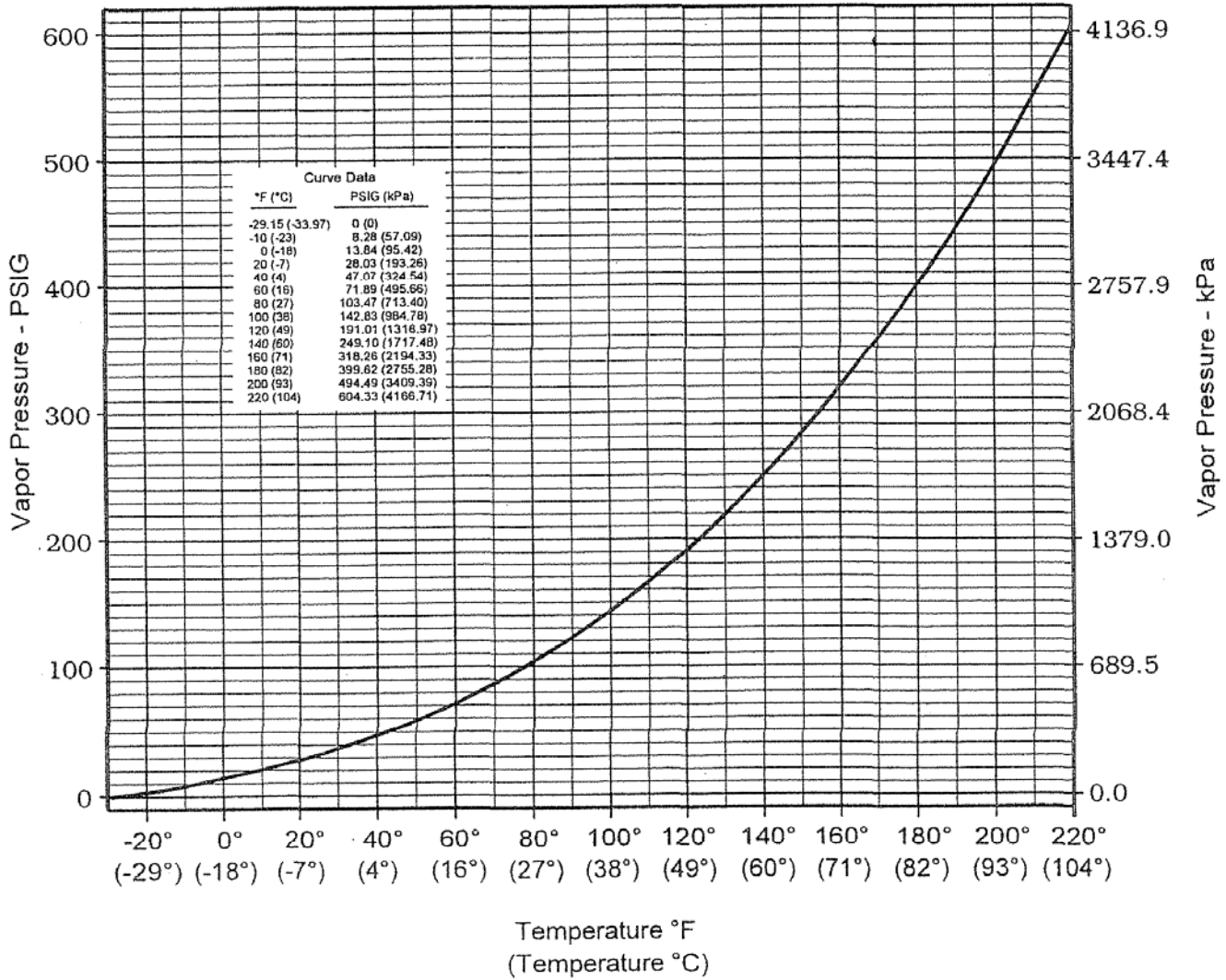

5.2.1 Metallic Piping

Dry chlorine is either gaseous or liquefied elemental chlorine with a very low water content. All chlorine commercially available in cylinders, ton containers, cargo tanks, and railroad tank cars is shipped as dry chlorine.

In general, ASTM A106 Grade B Schedule 80 seamless carbon steel piping is used when the process temperature range is -20°F to 300°F (-29°C to 149°C). Threaded or socket-welded construction can be used for pipe diameters of 1½ inches or less. Butt-welded and flanged joints can be used for all sizes of piping. Consult all applicable fire and building codes regarding the use of welded or flanged joints.

Certain metal piping materials, including titanium, aluminum, gold, and tin, **MUST NOT** be used with dry chlorine. Stainless steels are subject to chloride stress corrosion and should not be used in chlorine service. Even metals considered compatible with chlorine should never be heated when exposed to or containing chlorine. Many of these metals can burn in a chlorine atmosphere, releasing heat and metal chloride gases. (Note: iron and steel ignite with chlorine at about 483°F [226°C]). In addition, the corrosion rate of steel in a chlorine atmosphere increases significantly at temperatures above 250°F (121°C).

Piping systems must be thoroughly cleaned and dried before use (See CI Pamphlet 6).

Information on fittings, flanges, valves, nuts, bolts, flexible connectors, pipe dope and other fittings used in pressure piping can be found in Pamphlet 6. Lead and asbestos gaskets have been used. Further information on acceptable gasket materials is in Pamphlet 95. Refer to Pamphlet 164 for materials compatibility.

5.2.2 Nonmetallic Piping Systems

Plastic piping must never be used to transport liquid chlorine at treatment plants. Plastic piping is used only under specific conditions for gaseous chlorine and chlorine/water solutions after chlorine is injected from the chlorinator, or when the possibility exists for moisture to enter a system as in a gas chlorinator operation. Treatment plants use plastic piping primarily for the vacuum piping between the vacuum regulator and the ejector (injector) or for chlorine/water solution lines from the injector to the feed point. Where structural considerations are of concern, plastic-lined steel pipe may be required. Unlined steel cannot be used in a chlorine solution line.

Polyvinyl chloride (PVC), chlorinated polyvinyl chloride (CPVC), acrylonitrile-butadiene styrene (ABS), fiberglass-reinforced polyester (FRP), and polyethylene (PE) piping can be used under certain conditions (CI Pamphlet 6). Piping made of these materials is restricted to handling gaseous chlorine under vacuum or pressures up to 6 psig (41 kPa) maximum pressure. Plastic piping can become brittle in chlorine service and has a limited service life. Periodic inspection and replacement is recommended.

Most fluorocarbon plastic piping is also suitable for use with gaseous chlorine, but it should be used only under the same conditions as for other types of plastic pipes. Suitable fluorocarbon plastics include polytetrafluoroethylene (PTFE), perfluoroalkoxy (PFA), polyvinylidene fluoride (PVDF), and ethylene chlorotrifluoroethylene.

5.3 VACUUM SYSTEMS

Vacuum chlorinator systems operate under a vacuum that is created by water passing through a venturi. Many of the chlorinators that mount directly to cylinder and ton container valves are designed to close and stop the release of chlorine if vacuum is lost. This design can be a significant safety feature since any loss of vacuum, including a piping leak, will shut off the gas flow.

5.4 VAPORIZERS (EVAPORATORS)

Vaporizers (evaporators) are designed to convert liquid elemental chlorine into chlorine gas. Steam or hot water jackets are used to provide the heat needed for vaporization. Temperature control is critical. Pressure relief through the use of a safety valve with a rupture disk is required for vaporizers. Periodic cleaning is necessary and the manufacturer's recommendations should be followed (See CI Pamphlet 9).

5.5 TESTING CHLORINE FEED SYSTEMS

Chlorine systems require an extensive initial test before being placed in service, as well as periodic pressure testing throughout their service life. Vaporizers and chlorinators should be tested according to their manufacturers' recommendations. Piping systems should be tested according to the recommendations in CI Pamphlet 6. Flexible hoses, connectors, or pigtails should be visually inspected, pressure tested, and replaced according to the manufacturers' recommendations. Periodic inspection should be part of a preventive plant maintenance program. Replacement of flexible connectors is recommended annually as a minimum.

5.6 MANIFOLDING CYLINDERS AND TON CONTAINERS

Cylinders can be manifolded to withdraw gaseous chlorine. Ton containers can be manifolded to withdraw gaseous or liquid chlorine. Any manifolded cylinders or ton containers used for gas withdrawal should have the same liquid chlorine temperature. Liquid manifolding requires special procedures to prevent the possibility of transferring liquid chlorine from one manifolded container to another in the same manifold. The ton containers should be manifolded together via the vapor (upper) valves and separately manifolded via the liquid (lower) valves. After leak testing both manifolds, all of the vapor (upper) valves can be opened to equalize the internal pressures in the containers. The manifolded liquid (bottom) valves can then be opened to feed liquid chlorine to the vaporizer. CI Drawing 183, "Manifolding Containers for Liquid Chlorine Withdrawal," depicts the system needed if two or more ton containers are connected together for liquid withdrawal.

5.7 AUTOMATIC CONTAINER SHUT-OFF

The use of automatic shut-off devices should be considered. These include actuators that close the container valves as well as separate valves adjacent to or near the container valves. They can be operated both remotely and by the use of pressure-sensing switches or chlorine detectors. Such devices exist for all types of North American containers.

5.8 ROLE OF THE CHLORINE SUPPLIER

The supplier of chlorine and/or the supplier of your chlorination equipment can often help with understanding the safe operation, service, and maintenance of chlorine gas feed equipment (chlorinator) at water and wastewater treatment plants. The chemical supplier may often be a plant operator's first contact when assistance is needed.

6. CONNECTING AND UNLOADING TO THE SYSTEM

6.1 TYPES OF CONNECTIONS

6.1.1 Cylinders

Cylinders discharge gas when upright. When connected to the unloading system, the cylinder must be secured to prevent movement or falling. The use of load cells or scales is recommended to monitor the contents of the container during unloading.

A yoke and adaptor for use with CGA Connection 820 or 820C (either open or closed yoke) is the standard connection to the cylinder valve outlet. (See Figure 8) A gasket on the face of the valve is part of the connection, and a new gasket must be used each time a connection is made. The CGA Connection 660, which utilizes a threaded union that threads to the valve outlet, is not recommended for connecting to the cylinder valve.

Valve outlet threads are not standard tapered pipe threads and, therefore, are not suitable for use with standard pipe fittings.

A flexible connection should be used between the cylinder and piping system. Annealed copper tubing suitable for brazing is recommended. ASTM Specification B-88 is recommended provided the material furnished is of the proper dimensions. As an alternative, certain types of nonmetallic and metallic hoses are acceptable. The connection should be regularly inspected and replaced when deterioration is evident. It is very important to follow the recommendations on flexible hoses found in CI Pamphlet 6.

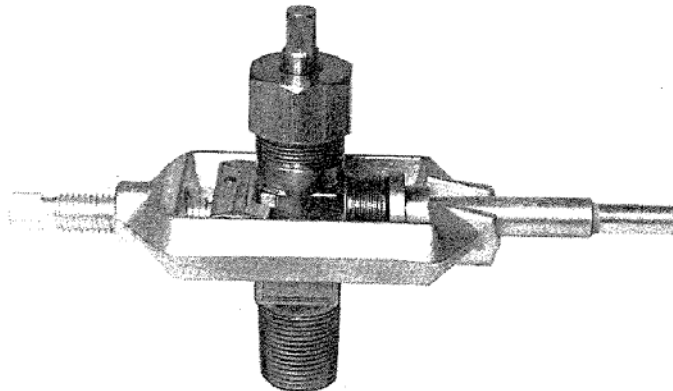

Figure 8 - Open Yoke Adapter - Type Connector

6.1.2 Ton Containers

Chlorine may be discharged as a liquid or a gas from ton containers. Ton containers are unloaded from a horizontal position, with the two discharge valves aligned vertically. The upper valve discharges gas and the lower valve discharges liquid chlorine. Containers should be held in a cradle or firmly secured to prevent rolling. A cradle with rollers makes it easy to rotate the container so that the two discharge valves are aligned vertically.

Ton containers use a valve similar to the cylinder valve. The major difference is the lack of a fusible plug in the valve body. The Institute recommends the use of the yoke and adaptor (CGA Connection 820 or 820C) as the standard connection to the container valve outlet. A gasket on the face of the valve is part of the connection, and a new gasket must be used each time a connection is made. The union threaded connection (CGA Connection 660) is not recommended for connecting to the unloading valve. Valve outlet threads are not standard tapered pipe threads. A flexible connection must be used between the ton container and piping system (Section 6.1.1).

6.1.3 Connecting/Disconnecting and Unloading Chlorine Containers

For vacuum regulators mounted to cylinders or ton containers, follow the manufacturer's procedures for connecting and disconnecting to the system. Otherwise, proceed according to the following subsection:

6.1.3.1 Cylinders and Ton Containers Unloading Gaseous or Liquid Chlorine

The cylinder or ton container must be secured properly. When connecting to the cylinder or ton container valve, the following precautions should be taken:

- Wear or equip yourself with the proper personal protective equipment (Section 8.2).
- Remove the valve hood or valve protection bonnet.
- Make certain that the packing nut is at least hand tight; if it is not, contact your supplier for advice.
- Make certain that the valve is closed before removing the outlet cap.
- Remove the valve outlet cap. Note that for ton containers with valves vertically aligned, the upper valves dispense gas and the lower valves dispense liquid.
- Make certain the valve face is clean and smooth.
- Use a new appropriate ring gasket to connect the yoke and the yoke adaptor to the valve. **Never reuse gaskets.**
- Tighten the yoke to make a seal, but do not over tighten.

6.1.3.2 Valve Operation/Unloading

- Using a wrench (50 ft/lbs maximum torque)/no longer than 8 inches, open the container valve to briefly introduce chlorine into the system and then close the valve. **Never use an extension (cheater) bar on the wrench.**
- Using only vapor from a 26 degree Baume or greater, aqua ammonia (ammonium hydroxide) solution (Section 4.3.1), test the yoke adaptor interface and the packing gland area for leaks. If any leaks are found, they must be remedied before proceeding (Subsection 4.3.1.1). Repeat this step if a leak was found.
- Using a wrench no longer than 8 inches, open the valve one complete turn. This is all that is required to achieve maximum gas flow rates.

- Open the appropriate valves in the piping system.
- Check again for leaks using only the vapors from an ammonia solution.

6.1.3.3 Disconnecting Cylinders and Ton Containers

Extreme caution must be exercised when disconnecting cylinders or ton containers that are not empty (If systems are equipped with automatic switch-over vacuum regulators, consult the manufacturer's literature for connection and disconnection procedures). This is especially critical in systems feeding liquid chlorine. Proceed with care as follows:

- Wear or equip yourself with the proper personal protection equipment (Section 9.2).
- Using a torque wrench, close the cylinder or ton container valve to a torque of 25 to 30 foot pounds.
- Let the pressure in the system drop to 0 psig by using the gas feed equipment to consume any residual chlorine, and apply a vacuum as appropriate for your systems design. When gauges indicate 0 psig or a vacuum, the appropriate piping system valve can be closed.
- If any leaks exist (the pressure increases in the line by the container), increase the torque to 40 foot pounds and retest for leaks. If the leak persists, use a maximum of 50 foot pounds of torque on the stem and repeat the above procedure.
- If the valve still leaks at 50 foot pounds, contact your supplier for advice.
- If the pressure in the line connected to the cylinder or ton valve remains constant at or below 0 psig, the yoke can be loosened and disconnected.
- Verify that an outlet gasket is in place and replace the valve outlet cap.
- Protect the yoke adaptor and chlorine line from the intrusion of moisture and moist air.
- Place a valve hood or bonnet on the cylinder or ton container as appropriate and mark as empty.
- Place the cylinder or ton container in an appropriate location for empty containers.

6.1.4 Tank Cars and Cargo Tanks

Chlorine tank cars must never be connected or unloaded by anyone not thoroughly trained about chlorine, the design of the car, and the unloading system. Each organization should have its own training program that covers these items. Pertinent details are beyond the scope of this document. See CI pamphlets 49 and 66. The chlorine supplier also can provide help with the training of personnel responsible for connecting to and unloading chlorine from a tank car or a cargo tank.

Opening the angle valve too quickly or allowing unusually high flow rates will cause the excess-flow valve to close. If this occurs, the angle valve should be closed and left closed until the metal ball in the excess-flow valve drops back into place with an audible click. If the ball does not fall into place, contact your chlorine supplier for advice. When unloading chlorine, the angle valve should be completely open and **never** used to control flow rate.

Automatic shut-off systems should be considered and may be required by local codes and regulations (CI Pamphlet 57).

6.2 VAPOR PRESSURE/TEMPERATURE RELATIONSHIP

A graph that shows the relationship between the chlorine vapor pressure and the temperature of the liquid chlorine is illustrated in Figure 7. From this figure it can be seen that the vapor pressure increases significantly as the chlorine temperature rises. Consequently, chlorine flow rates also can vary greatly depending on the temperature of the liquid chlorine.

It is possible that at very low temperatures a pressure gauge might read zero PSIG and indicate that a chlorine vessel is empty when, in fact, the chlorine vapor pressure is low due to the low temperature of the residual liquid chlorine in the container. A similar situation can occur if chlorine gas is withdrawn too quickly from cylinders and ton containers.

The remaining liquid chlorine can be cooled by the evaporating gas and result in reduced vapor pressure.

Tank cars and cargo tanks may need to be padded (CI Pamphlets 49 or 66) with oil-free dry air or nitrogen with -40°F (-40°C) dew point or lower to maintain acceptable unloading rates. If a tank car is padded and the liquid is piped to a vaporizer (evaporator), care should be taken in the vaporizing operation. This false high pressure will require more heat to raise the liquid temperature to the boiling (vaporizing) point. Liquid carryover could result. **Warning: Air padding is not an acceptable practice for unloading cylinders and ton containers.**

6.3 UNLOADING/FEED RATES

6.3.1 Cylinder Feed Rates

Chlorinator manufacturers use the approximation that cylinders of chlorine can be unloaded as a gas to a vacuum system at a continuous rate of 1 to 1.5 lb/day/ $^{\circ}\text{F}$ of ambient temperature. For example, a vacuum system at 70°F (21°C) ambient temperature can achieve a feed a rate of 70 to 105 lb (32 to 48 Kg) per 24 hours. Higher rates can be achieved for short periods of time, but the rate decreases as the vaporization cools the remaining liquid chlorine.

6.3.2 Ton Container Feed Rates

For discharging chlorine gas, a dependable continuous discharge rate is 6 to 8 lb/day/ $^{\circ}\text{F}$ into a line with a pressure less than 35 psi gauge (241 kPa). At 70°F (21°C), a discharge rate of 420 to 560 lb/day (191 to 255 Kg/day) can be achieved, and this rate may be greatly exceeded for short periods of time. A feed rate of 528 lb/day (240 Kg/day) is achievable when discharging into a vacuum chlorination system.

The dependable continuous discharge rate of liquid chlorine is at least 400 lb/hr (181 kg/hr) at 70°F (21°C) and against a discharge line pressure of 35 psi gauge (241 kPa).

Ton containers should never be padded with air or nitrogen.

6.3.3 Cargo Tanks and Tank Car Unloading Rates

The maximum flow for unloading cargo tanks and tank cars is determined by the rating of the excess flow valves. Cargo tanks are equipped with excess flow valves under all four angle valves. The liquid excess flow valves are rated at 7,000 lb/hr (3,200 kg/hr). Any instantaneous rate exceeding this value will seat the excess flow valve and stop the flow. (CI Pamphlet 49).

Tank cars are equipped with excess flow valves under the two liquid angle valves located on the longitudinal center of the car. They can be rated at either 7,000 lb/hr (3,200 kg/hr) or 15,000 lb/hr (6,800 kg/hr). While large-scale users may need to connect to both liquid valves for unloading, it is unlikely that a treatment plant would need to do this (CI Pamphlet 66).

7. BUILDING/STRUCTURE CONCERNS

7.1 DESIGN AND CONSTRUCTION

Local fire and building codes may dictate the legal requirements for buildings or other structures used to store or feed chlorine. Consultation with local government officials to determine what code and code year applies is essential. Buildings in which chlorine is stored should be made of noncombustible materials and should be free of flammable materials. Any building housing chlorine equipment or containers should be designed and constructed to protect all elements of the chlorine system from fire hazards.

If flammable materials are stored or processed in the same building, a fire wall should be erected to separate the chlorine from the flammables. Fire-resistant construction is recommended.

7.2 ELECTRICAL SYSTEMS

Chlorine is not classified as a flammable gas; therefore, no special code requirements exist with regard to electrical systems. However, chlorine gas is extremely corrosive and, in the event of a leak, the electrical system at a chlorine facility could be damaged by corrosion.

7.3 VENTILATION AND AIR OPENINGS

7.3.1 Ventilation

The Institute recommends that ventilation requirements be determined on a site-specific basis. Fire or building codes may dictate the minimum acceptable ventilation rate (See CI Pamphlet 65).

Safeguards should be in place to ensure that personnel without the appropriate personal protective equipment do not enter or remain in buildings where chlorine is present due to the potential of a leak or equipment failures.

7.3.2 Air Openings

Chlorine gas is heavier than air and will collect at floor level. The exhaust air intake should be located at or near floor level. The exhaust air discharge should be at a safe location. An elevated fresh-air inlet must be provided and should be positioned for adequate cross ventilation. Multiple fresh-air inlets and fans may be necessary to facilitate adequate ventilation. Fans, if used, should be operable from a safe remote location.

7.4 HEATING

Rooms in which chlorine containers are stored should be maintained at a normal indoor temperature of 60° to 70°F (15° to 20°C) to facilitate gas discharge rates from the containers. The chlorination equipment should be housed in a room at the same or higher temperature. However, the temperature in chlorine use and storage areas must never exceed 130°F (54°C).

7.5 ABSORPTION AND AUTOMATIC SHUT-OFF SYSTEMS

Local fire and building codes should be consulted to determine if scrubber systems are required. Scrubbers are devices that remove chlorine from the air, and they are effective for containing chlorine releases.

CI Emergency Kits or cylinder containment vessels and trained responders to stop or contain chlorine leaks are adequate for most locations (Sections 3, 4.3, and 9). Any requirements for scrubbers should be based on a risk assessment that considers the quantity of chlorine on site and the proximity to and potential impact on nearby populations and facilities.

Automatic actuators or valves can be located on or next to the cylinder or ton container valve. They can be activated by a chlorine detector, fire alarm, seismic detector, or by a remote switch. Automatic closure devices are now cited in I.C.C. and NFPA Fire and Building Codes.

7.6 SPRINKLER SYSTEMS

The Chlorine Institute does not recommend sprinklers for chlorine storage or use areas that are constructed of noncombustible materials and that are always free of flammable materials; however, some fire and building codes may still require them. If sprinklers are installed, they should be used only to suppress fires or to cool containers threatened by fire. Sprinklers are not effective in mitigating a chlorine leak or in serving as scrubbers. The presence of water (moisture) and chlorine can cause corrosion and exacerbate a leak.

7.7 EXITS AND WINDOWS

Exits should be clearly marked. All exit doors should open outward to the outdoors and should be equipped with anti-panic hardware that allows for easy opening. Internal exit doors are not recommended. Each room should contain at least one window so the interior can be viewed without entering the building. All windows should be made of fire-resistant, non-shattering material. Local fire and building codes also should be reviewed.

7.8 GAS DETECTION

Installations using or storing chlorine should have gas detection equipment in place to monitor for chlorine releases. Such equipment is particularly important when the facility is not staffed twenty-four hours a day. Chlorine detectors must be designed and adequately maintained to warn on-site personnel or to alert responders at a remote location of a release.

If the monitors are being used for leak detection as opposed to monitoring for Occupational Safety and Health Administration (OSHA) exposure limits (CI Pamphlets 1 or 65), different alarm settings may be required. Pertinent information should be available from the manufacturer of the detection equipment (CI Pamphlet 73).

8. **SECURITY**

Chlorine facilities should be protected against accidental or unauthorized entry. The vulnerability of each facility must be evaluated to determine the amount of security needed. The decision on the type of security will depend on factors such as location, proximity to other buildings, local codes, and so on. Buildings or areas should be surrounded by a fence, warning signs should be posted, and gates and doors should be locked. Access should be completely restricted and only personnel involved with the handling of the chlorine should be able to enter this area. (See CI Security Management Plan for the Transportation and On-Site Storage and Use of Chlorine Cylinders, Ton Containers and Cargo Tanks, August 15, 2003.)

9. **EMPLOYEE TRAINING, SAFETY, AND PERSONAL PROTECTION EQUIPMENT**

9.1 PLANT EMPLOYEE TRAINING

9.1.1 General

To a great extent, safety in handling chlorine depends on the effectiveness of employee training, proper safety instructions, and the use of suitable equipment. It is the responsibility of the employer to train employees, to document such training as appropriate and to ensure such training and documentation is in compliance with the regulations (See CI Pamphlet 85).

It is the responsibility of employees to carry out correct operating procedures safely and to properly use the safety equipment provided. The Chlorine Institute maintains numerous publications and other materials to aid end users in the development of meaningful training programs. See the Chlorine Institute Catalog for a complete listing.

OSHA regulations define the training requirements for emergency response personnel. The regulation identifies several training levels according to the emergency response task, each having minimum training requirements (See 29 CFR, 1910.120).

In addition to the OSHA training, at a minimum, chlorine employee training should include the following subjects:

- Chlorine properties (Sections 2.2 and 2.3)
- Health hazards (Section 2.3.3)
- Chlorine containers (Section 3)
- Transporting, storing, and handling of chlorine containers (Section 4)
- Connecting, disconnecting, and unloading chlorine containers (Section 6)
- Chlorine leaks (Section 4.3)
- First aid (Section 11)

9.1.2 Supplier Support

Equipment and chemical suppliers can be valuable sources of information. These companies frequently have safety and handling guides, pamphlets, videos, and other training materials for customer use. Similar information is available through various associations and national organizations (Sections 9.1 and 9.3, and Section 13.2.)

9.1.2.1 Material Safety Data Sheets and Other Literature

Suppliers are responsible for providing material safety data sheets (MSDS) that contain a detailed assessment of chemical characteristics, hazards, and other information relative to health, safety, and the environment. These sheets provide the following information:

- Identification of chemical composition, Chemical Abstract Service (CAS) number, formula, molecular weight, and synonyms.
- Physical data on boiling, freezing, and melting points, specific gravity, solubility, and vapor pressure.
- Reactivity information such as incompatibility, decomposition products, and polymerization potential.
- Health hazard data on effects of exposure (acute and chronic), permissible exposure limits, and warning signals.
- Environmental impact potential, such as effects on the environment, and shipping and other pertinent federal regulations.
- Exposure control methods, such as personal protective measures and engineering and administrative controls.
- Work practices, such as handling and storage procedures, normal cleanup, and waste disposal methods.
- Emergency procedures for handling spills, fires, and explosions, as well as first-aid procedures.

Such basic vital information must be readily accessible to all employees as a reference source.

9.1.2.2 Emergency Assistance

Some chlorine suppliers have technical expertise and equipment that can be made available to a customer during an emergency. The availability of such emergency assistance should be ascertained before you begin handling chlorine. If additional help is needed contact Chemtrec at 1-800-424-9300 (see Table 5 for Canada, Alaska and Hawaii.) Chemtrec will activate CHLOREP if needed.

9.1.3 Other Training Information Sources

The Chlorine Institute maintains training materials and other publications that may be found in the Chlorine Institute Catalog, which organizes subjects into industry specific sub-categories such as the Water and Wastewater industry (See Section 13.1.).

Table 5. Typical Emergency Action Checklist

<u>Action</u>	<u>Performed by</u>	<u>Date/Time</u>
Alert key plant personnel.	discoverer of the problem	
Activate emergency response team if on site.	plant operator	
Determine seriousness of situation.	plant operator	
Ensure that employees are located in a safe area, are properly equipped and protected, and that all are accounted for.	plant operator	
Alert appropriate off-site authorities.	plant operator	
Ensure that employees who may have been exposed receive medical surveillance and treatment if necessary.	plant operator	
Attempt to stop or control release.	response team	
Obtain outside assistance: Supplier or CHLOREP via CHEMTREC Continental U.S.: 1- 800-424-9300 Alaska, Hawaii, D.C.: 1- 703-527-3887 Canada: Call collect - 1- 613-996-6666	team	
Bring the incident under control.	on-site coordinator	
Determine when normal operations can resume.	on-site coordinator	
Provide close-out report of incident.	on-site coordinator	

9.2 PERSONAL PROTECTION EQUIPMENT AND SAFETY

9.2.1 General Recommendations

Employees with respiratory diseases or reduced respiratory capacity should avoid working in situations where chlorine exposure is possible. Chlorine users should adopt a medical surveillance program suitable to their needs (See CI Pamphlet 63).

9.2.1.1 Clothing

In the general areas of a facility or in buildings where chlorine is stored or used, no specialized clothing is required for workers performing routine plant operations. However, long pants, shirts with sleeves, safety glasses with side shields or *goggles approved for use with hazardous chemicals*, hard hats, and safety shoes should be worn or be available as dictated by plant practice. They should be free of oil and grease (See CI Pamphlet 65).

9.2.1.2 Respiratory Protection

All personnel entering areas where chlorine is stored or handled should carry or have immediately available an escape-type respirator. Chemical cartridge or full-face canister gas masks offer adequate temporary protection provided the oxygen content in the air is greater than 19.5% and the chlorine concentration does not exceed the rated capacity of the respirator. The need to protect the eyes from chlorine should be part of the evaluation of appropriate respiratory equipment.

Pressure-demand self-contained breathing apparatus (SCBA), with full face piece, is required for performing tasks when chlorine may be present unless air sampling verifies the chlorine concentration is such that a lower level of respiratory protection is adequate. Emergency responders must have regularly scheduled and documented training to assure competency with SCBA. This SCBA apparatus should be located on site or at acceptable locations. If arrangements have been made to use an approved outside emergency response group, then the responders and apparatus may be located off site.

Fit testing and regular maintenance programs for respirator equipment are required and must be documented (29 *CFR* 1910.134(f) and Appendix A, (h) and (m)) (See CI Pamphlet 65).

9.2.2 Specific Recommendations

This section addresses only the need for personal protective equipment (PPE) in connection with initial line breaks and the routine operations of unloading containers performed by treatment plant personnel. Emergency response operations are covered in Section 9.

These recommendations should supplement the facility's:

- written operating and maintenance procedures
- emergency response plan (ERP)
- established programs for training employees

It is assumed that the facility has performed a detailed job safety analysis of the specific task being performed. If an analysis concludes that a lower level of PPE is adequate for the employee(s) performing the operations, such lower level PPE must be fully compatible with these recommendations.

9.2.2.1 Line Break

A line break is defined as the opening of a line, section of a line, a vessel, or other equipment that contains or previously contained chlorine and includes equipment that was returned to chlorine service and is reopened to the atmosphere. An initial line break is considered a maintenance activity and does not include the act of connecting or disconnecting containers for loading and/or unloading purposes or material sampling activities.

For line breaks that have been routinely performed in the past, and have demonstrated that the evacuation techniques and maintenance procedures utilized do not result in chlorine concentrations that exceed either the OSHA ceiling limit or the safety rating of the respirator, then the following PPE recommendations apply (See CI Pamphlet 65):

- For chlorine gas, use a full-face air purifying respirator
- For chlorine liquid, use a full-face air purifying respirator and gloves that provide thermal protection.

9.2.2.2 Unloading Chlorine

For a facility that meets the following:

- Is experienced in the unloading of chlorine;
- Is equipped with a system for purging and evacuating piping, hoses and other unloading equipment;
- Has had an industrial hygiene sampling performed which supports that the techniques in place result in a chlorine concentration below the time-weighted average (TWA) and the short term exposure ceiling (STEL);
- Has written operating and maintenance procedures;
- And has trained their employees.
- For chlorine gas, no specialized PPE is needed
- For chlorine liquid, no specialized PPE is needed

If loading/unloading procedures result in a chlorine concentration that exceeds the TWA level or the STEL ceiling, but does not exceed the safety rating of the respirator, then the following recommendations apply (See CI Pamphlet 65):

- For chlorine gas, use a full-face air purifying respirator
- For chlorine liquid, use a full-face air purifying respirator and gloves that provide thermal protection

If testing or evaluation work has not been performed, or if performed with results that show chlorine levels exceeded the safety rating of the respirator, then these recommendations apply (See CI Pamphlet 65):

- For chlorine gas, use an air supply respirator
- For chlorine liquid, use an air supply respirator and gloves that provide thermal protection

9.3 OTHER SAFETY EQUIPMENT

An emergency eyewash and a deluge shower should be located near the potential exposure site but not so close as to be unusable in an emergency. The path to the unit must remain clear of all obstructions. There are OSHA standards that define eyewash/safety shower parameters, i.e., flow rates and temperature along with other considerations such as protection against freezing (29 *CFR* 1910.151(c)).

10. **HANDLING EMERGENCIES**

10.1 PLANNING

The presence and use of chlorine can be a potential hazard to both facility employees and the surrounding community. In recognition of this potential, federal law and many state laws require that written emergency plans be developed to prevent, mitigate, and guide response to a chlorine release. There are at least two planning efforts required for each water or wastewater treatment facility: one that addresses protecting the community from a chlorine release and one for protecting employees.

Before an emergency plan is written, a risk assessment for the facility is recommended. A risk assessment is the process of collecting and analyzing information in order to determine what chemical hazards and process risks are present at a facility that could impact employees or the public. Sites with more than 1,500 lb of chlorine in a single process are required to do a risk assessment under the Process Safety Management (PSM) regulations stipulated by OSHA in Section 1910.119 of 29 *CFR* (Appendix C). The Environmental Protection Agency (EPA) requires a risk management plan (RMP) for sites where chlorine exceeds 2,500 lb in a single process, as given in 40 *CFR* 68 (Appendix D).

At the time this document was published, there were two generic RMPs involving chlorine that could provide information useful in preparing plans suited to specific facilities. One, designed for treatment plants, was prepared by the EPA and the Research Foundation of the American Water Works Association (AWWA), *The Risk Assessment Methodology for Water Utilities* (2003). The other, available from the Chlorine Institute (CI Pamphlet 162), applies to chlorine packaging plants and sodium hypochlorite manufacturers. These plans can assist in preparing RMP plans for treatment plants.

RMP planning must include consideration for monitoring, detection, and alarm equipment. Selection of the appropriate emergency personnel, assignment of responsibilities, quantity release estimate, mutual assistance (supplier, hazardous materials [HAZMAT] teams, fire departments, etc.), necessary notification requirements (facility and off site), decision making, first-aid needs, and containment should be covered in a set of procedures included in the written plan.

Additional planning considerations should include the technical expertise, scientific instrumentation, heavy equipment, and transportation vehicles that may be needed during an emergency. An inventory of locally available items should be accessible to responders. Likewise, the locations of emergency kits for cylinders, ton containers, cargo tanks, and rail cars should be known. The availability of emergency breathing apparatus, showers, and eye-wash stations and their locations should be known.

10.2 ESTABLISHING PROCEDURES

Emergency response procedures are concerned with the efforts of employees from outside the immediate release area or by other designated responders in dealing with an occurrence that results, or is likely to result, in an uncontrollable release of a hazardous substance. Responses to incidental releases of hazardous substances where the substance can be absorbed, neutralized, or otherwise controlled at the time of release by the employees in the immediate release area or by maintenance personnel are not considered to be emergency responses (29 *CFR* 1910.120).

The procedures established should outline the proper coordination and communication between plant personnel, their plant management, and outside agencies. Community response personnel must include fire department, police department, emergency medical personnel, and HAZMAT teams at the least. State or local regulations may have additional requirements.

Each treatment plant should develop its own emergency action checklist, which should be readily available for facility personnel to aid in response. Table 5 lists typical key actions that are to be taken in the event of a chlorine emergency. It should be considered as a guide to aid the treatment plant operator. More detailed assistance is available from OSHA, EPA, and state regulatory agencies.

Assistance and information during the planning process is available from your chlorine suppliers and CI Pamphlet 64. In an emergency situation, responders should be called in the order dictated in your emergency response plan (ERP). These may include the fire service, your chlorine supplier, or another local emergency response team. If you cannot obtain assistance during an emergency, you can contact Chemtrec by calling the toll-free number on your shipping papers (see Table 5). Chemtrec is primarily designed to assist in transportation emergencies and should be used in other situations only as a last resort.

10.3 TRAINING

10.3.1 Materials and Sources

Training programs and materials are available from a variety of sources, including chlorine suppliers, state and local government agencies, and organizations such as the CI, AWWA, WEF, and NFPA. The best starting point for identifying training resources is the local emergency planning committee (LEPC) for your area (Contact your State Emergency Response Commission for LEPC information) as well as your supplier. (See CI W-Video.)

10.3.2 Facility Personnel

Treatment plant employees should be trained in the emergency response plan, in safety procedures for the handling and use of chlorine, and in the use of self-contained breathing apparatus and other applicable equipment. The training requirements depend on the specific employee's roles and responsibilities. Each plant should have a training program customized to its specific needs depending on the type of facility, type and number of chlorine containers, and number of employees. The site should keep written documentation of all training.

10.3.3 Emergency Responders

Emergency responder training requirements are based on the response level (Table 6) and type of job responsibility assigned to each responder. The following list includes the various response levels of those who may be present at the site of an emergency, and brief descriptions of their responsibilities:

- **First Responder, Awareness Level:** Persons who, in the course of their normal duties, may be first on the scene of an emergency involving a hazardous substance. They are expected to notify the proper authorities as indicated in the plant's emergency response plan and take no further action.
- **First Responder, Operations Level:** Persons involved in the initial response to a release or potential release of hazardous substances for the purpose of protecting nearby persons, the environment, or property from the effects of the release. They are trained to respond defensively without actually trying to stop the release. Their function is to contain the release from a safe distance, keep it from spreading, and prevent exposures.
- **Hazardous Materials Technician:** Persons who respond to a release or potential release for the purpose of stopping the release. They assume a more aggressive role than first responders at the operations level do in that they will approach the point of release and attempt to plug, patch, or otherwise stop the release.
- **Hazardous Materials Specialist:** Persons who respond with and provide support to hazardous materials technicians. Their duties parallel those of the technicians but require a more specific knowledge of the various substances they may be called on to contain. The specialist also may act as the site liaison with federal, state, local, and other government authorities regarding site activities.
- **On-Scene Incident Commander:** The person who is responsible for directing and coordinating all aspects of a hazardous incident.
- **Skilled Support Personnel:** Persons who are skilled in operating certain equipment (e.g., backhoe or crane) and are needed temporarily to perform immediate emergency support work.
- **Specialist Employees:** Persons who, in the course of their regular job duties, work with and train in the hazards of specific hazardous substances, and who may be called on to provide technical advice or assistance.

It is beyond the scope of this pamphlet to provide the details of a training program for emergency responders; however, a summary of the training requirements is given in Table 6. Actual training requirements for each level of responder are given in 29 *CFR* 1910.120. Because these regulations change, you should review 29 *CFR* periodically.

Table 6. Summary of HAZMAT Responders Training Requirements

Response Level	Minimum Training Requirement
Awareness level	Understanding of hazardous materials, including their risks, and of how to secure the site and notify others in case of an emergency
First responder, operations level	8 hours of training, including awareness-level topics
Hazardous materials technician	24 hours of training, including operations-level topics
Hazardous materials specialist	24 hours of training equal to technician-level competency
On-scene incident commander	24 hours of training equal to operational level plus competency in commanding incidents and implementing emergency response plans
Skilled support personnel	Initial pre-entry briefing
Specialist employees	Annual training and competency in area of specialization

10.4 AUDITS AND EXERCISES

An effective way to determine the adequacy of a treatment plant emergency plan is to have periodic audits and exercises. Audits should be performed with various facility response personnel to test their knowledge of duties and equipment, along with periodic auditing on actual use of the equipment. Exercises should be conducted to test the participants' reactions and effectiveness in implementing the emergency plan as well as to test the actual mechanics of the plan.

There are basically three types of exercises: the full-scale exercise, the in-plant exercise, and the table-top exercise. Consideration should be given to conducting full-scale exercises utilizing responders from the community at least once a year. Periodic in-plant exercises should use different simulated events and involve as many of the various personnel as possible. These exercises should be conducted similarly to full-scale exercises but would not involve outside emergency personnel.

Table-top exercises should be conducted periodically to check the ability of the emergency response crews to analyze an event, communicate effectively to outside emergency response personnel, and respond to unfolding events. This type of exercise is usually conducted with just the supervisors of key emergency response personnel, both in-plant and from outside agencies.

Following any of the exercises, a critique should be made to assess the effectiveness of the plan and to pinpoint any weaknesses in it or in the training and knowledge level of the personnel involved. A written report of the exercise should be available for review and the facility's emergency plan should be modified as needed.

11. MEDICAL ASPECTS

11.1 HAZARDS TO HEALTH

11.1.1 General

Chlorine gas is primarily a respiratory irritant. At low concentrations chlorine gas has an odor similar to household bleach. As the concentrations increase from the level of detection by smell, so does symptomatology in the exposed individual. At chlorine concentrations above 5 ppm the gas is very irritating, and it is unlikely that any person would remain in such an exposure for more than a very brief time unless the person is trapped or unconscious. If the symptoms persist for more than a few hours, the effects of exposure to chlorine may become more severe for several days after the incident. In such cases, observation of exposed individuals should be a part of the medical response program (See CI Pamphlet 63 for more detailed information).

The following list is a compilation of chlorine exposure thresholds and reported responses in humans (with considerable variation among subjects):

Table 7. Chlorine Exposure Thresholds and Reported Responses

0.2 – 0.4	Odor threshold (decrease in odor perception occurs over time)
1 – 3 ppm	Mild mucous membrane irritation, tolerated up to 1 hour
5 – 15 ppm	Moderate irritation of the respiratory tract. The gas is very irritating, and it is unlikely that any person would remain in such an exposure for more than a very brief time unless the person is trapped or unconscious
30 ppm	Immediate chest pain, vomiting, dyspnea, cough
40 – 60 ppm	Toxic pneumonitis and pulmonary edema
430 ppm	Lethal over 30 minutes
1000 ppm	Fatal within a few minutes.

11.2 ACUTE TOXICITY

11.2.1 Respiratory/Cardiovascular

The toxic effects of chlorine are due to its corrosive properties. Chlorine is water soluble and primarily removed by the upper airways. As indicated above, exposure to low concentrations of chlorine gas may cause nasal irritation as well as irritation of the mucous membranes of the respiratory tract. As concentrations increase, there is an increase in the irritating effect on the upper and lower respiratory tract manifested as coughing with eventual difficulty in breathing. Inhalation of chlorine gas (>15 ppm) may lead to respiratory distress associated with airway constriction and accumulation of fluid in the lungs (pulmonary edema).

As the duration of exposure and/or the concentration increase, the affected individual may develop the immediate onset of rapid breathing, wheezing, rales, or hemoptysis. In extreme cases difficulty in breathing can progress to the point of death through cardiovascular collapse from respiratory failure. An exposed person with a pre-existing respiratory condition can have an exaggerated response. Cases of Reactive Airways Dysfunction Syndrome (RADS), a chemical irritant-induced type of asthma, have been reported.

11.2.2 Dermal

Liquid chlorine in contact with the skin will cause local chemical or thermal (frostbite) burns. Gaseous chlorine in contact with the skin can dissolve in body moisture (i.e., perspiration) to form hypochlorous and hydrochloric acids. At 3,500 ppm chlorine in air, the pH of moisture on the skin would be approximately 4. A pH of 4 is comparable to carbonated water. While a burning sensation and skin irritation can occur due to such exposure, a review of the literature has provided no specific human data to determine the concentration of chlorine required to produce such effects.

11.2.3 Eyes

Low concentrations of chlorine in the air can result in eye irritation, associated burning discomfort, spasmodic blinking, redness, conjunctivitis and tearing. Exposure to higher concentrations of gaseous chlorine may result in more serious injuries. Liquid chlorine in contact with the eyes will result in serious thermal and/or chemical burns.

11.3 CHRONIC TOXICITY

Most studies indicate no significant connection between adverse health effects and chronic exposure to low concentrations of chlorine.

11.4 CI HEALTH VIDEO

A health video, outlining the short term health effects is available from The Chlorine Institute. (See H-VIDEO or H-DVD.)

12. FIRST AID

First aid is the immediate temporary treatment given to an exposed individual. Prompt action is essential. Reassurance to the individual will help to alleviate anxiety. When indicated, medical assistance must be obtained as soon as possible. Never give anything by mouth to an unconscious or convulsing person. If chlorine has saturated an exposed individual's clothes and/or skin, decontamination should be done by removing affected clothing and showering as appropriate. (See CI Pamphlet 63 for more detailed information.)

Responders should take the necessary precautions to protect themselves from any exposure to chlorine while administering first aid and should move the victim from any contaminated area as quickly as possible.

12.1 INHALATION

An individual with chlorine exposure should be evaluated for adequate airway, breathing and circulation after the inhalation. If breathing has apparently ceased, the victim should be given cardiopulmonary resuscitation (CPR) immediately. If breathing has not ceased, the exposed individual should be placed in a comfortable position. The person should sit in an upright position with the head and trunk elevated to a 45-60 degree position (unless there is a medical contraindication). Slow, deep breathing should be encouraged. Vital signs (respiratory rate, pulse, and blood pressure) and oxygen saturation should be obtained if trained personnel and equipment are available.

Suitable equipment for the administration of oxygen should be available either on site or at a nearby facility. Such equipment should be periodically tested.

Historically, oxygen therapy, specifically humidified oxygen, has been considered the primary treatment for chlorine inhalations. Humidified oxygen is preferred since the humidity soothes the irritation to the mucous membranes caused by the chlorine. Oxygen without the humidity can have a drying effect, thus potentially aggravating the irritant symptoms. However, if humidified oxygen is not available, oxygen without the humidity should not be withheld if oxygen therapy is indicated. With the advance in technology, equipment (pulse oximeter) is now available which can quickly measure the oxygen saturation in an individual. This measurement may be helpful in deciding whether supplemental oxygen is needed after a chlorine inhalation.

Oxygen therapy may not be necessary for all cases of chlorine inhalation. However, in any case in which an individual with a chlorine inhalation continues to be symptomatic after leaving the area of exposure, oxygen therapy is recommended unless it can be determined that it is not needed. **The circumstances in which oxygen therapy is not needed should be defined in advance by a physician, based on the clinical findings and a case by case determination made by first aid providers specifically trained in this area.**

12.1.1 Administration of Oxygen

Oxygen should be administered by first aid providers trained in the use of the specific oxygen equipment under the guidance of a licensed health care professional.

If a pulse oximeter is not available, oxygen therapy is recommended for any individual who has inhaled chlorine and continues to be symptomatic after leaving the area of exposure.

If a pulse oximeter is available, the following findings comprise a base list of situations in which oxygen therapy is generally indicated to be given by first aid providers after a chlorine inhalation. Other criteria may be added to this list if specifically recommended by a physician:

- Sustained pulse-oximetry readings <92%; or
- The individual is in obvious respiratory distress (including, but not limited to rapid respirations, difficulty breathing, using accessory muscles for respiration, continuous uncontrollable coughing, wheezing); or
- The exposed individual is having “symptoms of concern”, such as significant chest pain/tightness, extreme weakness, altered/declining mental status, or the individual is diaphoretic (clammy/pale/sweating not due to environmental conditions) etc., especially if these or other significant symptoms occur with an individual with a past history of cardiac problems or asthma ; (Note: “symptoms of concern” generally do not include the typical upper respiratory tract irritation symptoms which occur with mild chlorine gas inhalations such as mild/moderate coughing, initial difficulty “catching one’s breath”, mild/moderate shortness of breath, irritated throat, runny nose, congestion, headache, and/or mild nausea)

Note: It is recommended that a physician be consulted regarding any individual meeting one or more of the above criteria in order to determine whether further evaluation and or treatment is indicated.

If oxygen therapy is indicated, it should be administered until the symptoms resolve. Whenever oxygen is discontinued after symptoms resolve, the individual should then be observed for 30-60 minutes while breathing room air. If significant symptoms do not resolve within 60 minutes of oxygen therapy, or symptoms return/worsen and/or the oxygen saturation (when pulse oximetry is available) falls below 92%, it is recommended that oxygen therapy be restarted (if it had been discontinued) and further evaluation by a physician be provided.

12.1.2 Administration of Humidified Breathing Air

Not all individuals who have inhaled chlorine require oxygen therapy. It is recommended that the circumstances in which oxygen therapy is not needed should be defined in advance by a physician and a case by case determination made by first aid providers specifically trained in this area.

In situations where it has been determined that oxygen therapy is not needed, but the individual with an inhalation exposure has irritant symptoms, humidified air may be provided for symptomatic care. While breathing humidified air, the individual should be closely monitored for 30 - 60 minutes. If the individual continues to show no signs or symptoms for which oxygen would be indicated, the humidified air can be stopped. Observation should continue for an additional 30 minutes while the individual is breathing room air so as to insure that there is no deterioration of the individual's condition. Oxygen therapy should be started at any time during the above process if symptoms worsen to the point that oxygen is indicated. Further evaluation by a physician should be provided in any case in which oxygen therapy is provided.

12.1.3 Symptomatic care

Other symptomatic care measures, such as cool compresses to the face and over-the-counter medications, may help to minimize symptoms. Over-the-counter medications which may be helpful include:

- Irritated/sore throat – throat lozenges
- Dry cough – dextromethorphan, guaifenesin
- Headaches – acetaminophen, aspirin, ibuprofen
- Upset stomach – antacids

12.2 CONTACT WITH SKIN

If liquid chlorine has contaminated the skin or clothing, an emergency shower should be used immediately and contaminated clothing should be removed under the shower. Flush contaminated skin with copious amounts of tepid water for 15 minutes or longer. Thermal burns, due to the cold temperature of liquid chlorine, may be more damaging than any chemical reaction of chlorine and the skin. Exposure to gaseous chlorine can irritate the skin. Do not attempt chemical neutralization or apply any salves or ointments to damaged skin. Refer to a qualified health care provider if irritation persists after irrigation or if skin is broken or blistered.

12.3 CONTACT WITH THE EYES

If the eyes have been irritated due to exposure to chlorine, they should be flushed immediately with copious quantities of tepid water for at least 15 minutes.

- ▶ Never attempt to neutralize with chemicals.

The eyelids should be held apart during this period to ensure contact of water with all accessible tissue of the eyes and lids. Medical assistance must be obtained as soon as possible. If such assistance is not immediately available, eye irrigation should be continued for a second 15-minute period. Nothing but water should be applied unless ordered by a qualified health care provider.

13. REFERENCES

13.1 CI PUBLICATIONS

- * *The Chlorine Manual*, ed. 6; Pamphlet 1; The Chlorine Institute: Arlington, VA, **1997**.
- Bulk Storage of Liquid Chlorine*, ed. 7; Pamphlet 5; The Chlorine Institute: Arlington, VA, **2005**.
- Piping Systems for Dry Chlorine*, ed. 15; Pamphlet 6; The Chlorine Institute: Arlington, VA, **2005**.
- Chlorine Vaporizing Systems*, ed. 6; Pamphlet 9; The Chlorine Institute: Arlington, VA, **2002**.
- Packaging Plant Safety and Operational Guidelines*, ed. 3-R1; Pamphlet 17; The Chlorine Institute: Arlington, VA, **2002**.
- Recommended Practices for Handling Chlorine Bulk Highway Transports*, ed. 8; Pamphlet 49; The Chlorine Institute: Arlington, VA, **2001**.
- Emergency Shut-Off Systems for Bulk Transfer of Chlorine*, ed. 4; Pamphlet 57; The Chlorine Institute: Arlington, VA, **2003**.
- * *First Aid, Medical Management / Surveillance and Occupational Hygiene Monitoring Practices for Chlorine*, ed. 7; Pamphlet 63; The Chlorine Institute: Arlington, VA, **2003**.
- Emergency Response Plans for Chlor-Alkali, Sodium Hypochlorite, and Hydrogen Chloride Facilities*, ed. 6; Pamphlet 64; The Chlorine Institute: Arlington, VA, **2006**.
- * *Personal Protective Equipment for Chlor-Alkali Chemicals*, ed. 4; Pamphlet 65; The Chlorine Institute: Arlington, VA, **2001**.
- Recommended Practices for Handling Chlorine Tank Cars*, ed. 4; Pamphlet 66; The Chlorine Institute: Arlington, VA, **2007**.
- * *Atmospheric Monitoring Equipment for Chlorine*, ed. 7; Pamphlet 73; The Chlorine Institute: Arlington, VA, **2003**.
- Guidance on Complying with EPA Requirements Under the Clean Air Act by Estimating the Area Affected by a Chlorine Release*, ed. 4-R1; Pamphlet 74; The Chlorine Institute: Arlington, VA, **2006**.
- Guidelines for the Safe Motor Vehicular Transportation of Chlorine Cylinders and Ton Containers*, ed. 4; Pamphlet 76; The Chlorine Institute: Arlington, VA, **2007**.
- * *Recommendations for Prevention of Personnel Injuries for Chlorine Producer and User Facilities*, ed. 4; Pamphlet 85; The Chlorine Institute: Arlington, VA, **2005**.
- Chlorine Scrubbing Systems*, ed. 3; Pamphlet 89; The Chlorine Institute: Arlington, VA, **2006**.
- Gaskets for Chlorine Service*, ed. 3; Pamphlet 95; The Chlorine Institute: Arlington, VA, **2003**.

Dry Chlorine: Definitions and Analytical Issues, ed. 3; Pamphlet 100; The Chlorine Institute: Arlington, VA, **2002**.

Generic Risk Management Plan for Chlorine Pkg Plants & Sodium Hypochlorite Production Facilities, ed. 2-R1; Pamphlet 162; The Chlorine Institute: Arlington, VA, **2004**.

Reactivity and Compatibility of Chlorine and Sodium Hydroxide with Various Materials, ed. 2; Pamphlet 164; The Chlorine Institute: Arlington, VA, **2007**.

Learning From Experience, ed. 1; Pamphlet 167; The Chlorine Institute: Arlington, VA, **2002**.

Instruction Booklet: How to Use the Chlorine Institute Emergency Kit "A" for 100-lb, and 150-lb. Chlorine Cylinders, ed. 10; Pamphlet IB/A; The Chlorine Institute: Arlington, VA, **2003**

How to Use the Chlorine Institute Emergency Kit "A" for 100-lb and 150-lb Chlorine Cylinders, Video, ed. 2; A-VIDEO, A-DVD (Spanish: A-VIDEO-S, A-DVD-S); The Chlorine Institute: Arlington, VA, **1996**

Instruction Booklet: CI Recovery Vessel for 100-lb and 150-lb Chlorine Cylinders, ed. 1; Pamphlet IB/RV; The Chlorine Institute: Arlington, VA, **1992**

Instruction Booklet: Chlorine Institute Emergency Kit B for Chlorine Ton Containers, ed. 9; Pamphlet IB/B; The Chlorine Institute: Arlington, VA, **2003**

How to Use the Chlorine Institute Emergency Kit B for Chlorine Ton Containers, ed.2; B-VIDEO, B-DVD; The Chlorine Institute: Arlington, VA, **2006**

Instruction Booklet: Chlorine Institute Emergency Kit C for Chlorine Tank Cars and Tank Trucks, ed. 8-R1; IB/C; The Chlorine Institute: Arlington, VA, **2006**

How to Use the Chlorine Institute Emergency Kit C for Chlorine Tank Cars and Tank Trucks, ed. 1; C-VIDEO, C-DVD (Spanish: C-VIDEO-S, C-DVD-S); The Chlorine Institute: Arlington, VA, **2005**

Health Effects from Short-Term Chlorine Exposure, ed. 1; H-VIDEO, H-DVD; The Chlorine Institute: Arlington, VA, **1994**

Chlorine Safety for Water and Wastewater Operators, ed. 1; W-VIDEO, W-DVD (Spanish: W-VIDEO-S, W-DVD-S); The Chlorine Institute: Arlington, VA, **1999**

Chlorine Emergencies: An Overview for First Responders; DVD; The Chlorine Institute: Arlington, VA, **2007**

Wall Chart: Handling Chlorine Cylinders and Ton Containers (English and Spanish), ed. 2; WC-1; The Chlorine Institute: Arlington, VA, **2001**

CI Security Management Plan for the Transportation and On-Site Storage and Use of Chlorine Cylinders, Ton Containers and Cargo Tanks, August 15, 2003. [Contact CI Staff]

*** A Free Publication: These publications may be downloaded free from CI's website: www.chlorineinstitute.org.**

13.2 DIRECTORY OF ORGANIZATIONS

American Conference of Governmental
Industrial Hygienists
1330 Kemper Meadow Drive
Cincinnati, OH 45240
513-742-2020
www.acgih.org

American Chemistry Council
1300 Wilson Boulevard
Arlington, VA 22209
703-887-1272
www.americanchemistry.com

Compressed Gas Association
1725 Jefferson Davis Highway
Crystal Square 2, Suite 1004
Arlington, VA 22202-4102
703-412-0900
www.cganet.com

Chemical Industry Institute of Toxicology
P.O. Box 12137
Research Triangle Park, NC 27709
919-558-1200
www.thehamner.org

Water Environment Federation
601 Wythe Street
Alexandria, VA 22314
1-800-666-0206
www.wef.org

American Water Works Association
6666 West Quincy Avenue
Denver, CO 80235
303-794-7711
www.awwa.org

The Chlorine Institute Inc.
1300 Wilson Boulevard
Arlington, VA 22209
703-741-5760
www.chlorineinstitute.org

International Code Council
500 New Jersey Avenue, NW/6th Floor
Washington, DC 20001
1-888-422-3233
www.iccsafe.org

National Fire Protection Association
1 Batterymarch Park
Quincy, MA 02169-7471
617-770-3000
www.nfpa.org

United States Environmental Protection Agency
1200 Pennsylvania Avenue, NW
Washington, DC 20460
202-564-5700 (Office of Water)
202-564-8600 (Office of Emergency
Management)
www.epa.gov

APPENDIX A

SARA TITLE III REPORTING REQUIREMENTS

The Emergency Planning and Community Right-to-Know Act (EPCRA) is also known as Title III of the Superfund Amendments and Reauthorization Act (SARA) of 1986 (42 *CFR*). Five sections of this act apply to water and wastewater treatment facilities. They are summarized as follows:

- Section 302 requires that any facility having on its premises more than 100 lb of chlorine must report this fact to the State Emergency Response Commission. This is a one-time reporting requirement. Other extremely hazardous substances not typically found at treatment facilities must also be reported.
- Section 303 requires that any facility that has reported in accordance with section 302 must provide to the local emergency planning committee (LEPC) the name of its facility emergency coordinator who will participate with the LEPC in the emergency planning process. The facility must also provide to the LEPC any information requested for plan development and implementation.
- Section 304 requires that any facility that releases 10 lb or more of chlorine into the environment must immediately report the release to the community emergency coordinator, the state, and the National Response Center. The initial contact of this notification must be followed-up by a written notification to the same parties. The contents of the notification are also stipulated in this section. The routine release of chlorine into water and wastewater for treatment purposes does not have to be reported. Failure to report to the National Response Center (800-424-8802) in a timely manner (as soon as an RQ is believed to be exceeded and absolutely within a 24-hour time frame) can result in criminal and civil penalties. (See CI Pamphlet 64.)
- Section 311 requires that any facility having 100 lb of chlorine on its premises at any one time must submit a material safety data sheet (MSDS) for chlorine, or a list of the hazardous chemicals, including chlorine, that are on its premises, to the local fire department, the local emergency planning committee, and the State Emergency Response Commission. If an MSDS is submitted, it must be resubmitted whenever there is a significant change in it.
- Section 312 requires that any facility having 100 lb of chlorine on its premises at any one time during a calendar year must prepare and submit, before March 1 of the following year, an Emergency and Hazardous Chemical Inventory Form (either Tier I or Tier II) to the State Emergency Response Commission, the emergency planning committee, and the local fire department. This is an annual requirement.

For further information on the EPCRA law, contact your local emergency planning committee of the State Emergency Response Commission.

APPENDIX B

OCCUPATIONAL SAFETY AND HEALTH ADMINISTRATION REGULATIONS

The following sections of Title 29 of the *Code of Federal Regulations (29 CFR)* are pertinent to the operation of facilities utilizing chlorine as part of the process.

29 CFR 1910.120: Hazardous Waste Operations and Emergency Response

Any facility having an extremely hazardous substance, such as chlorine, on its premises must develop an emergency response plan and train its employees in the implementation of that plan.

Each employer shall develop an emergency response plan that shall address, at a minimum, the following elements:

Pre-emergency planning and coordination with outside parties. Personnel roles, lines of authority, training and communication. Emergency recognition and prevention.

Safe distances and place of refuge.

Site security and control.

Evacuation route and procedures.

Decontamination.

Emergency medical treatment and first aid.

Emergency alerting and response procedures.

Critique of response and follow-up.

Personal protective equipment (PPE) and emergency equipment.

29 CFR 1910.1200: Hazard Communications

Employers shall provide employee training on the chemical hazards that may be encountered on the job. The training program must contain the following items:

Guidance on how to read and understand the MSDS.

Information on the location of the facility's emergency response plan and what the employees' responsibilities would be during an emergency.

Education as to the physical and health hazards of chlorine gas and any other hazardous material that may be present in the employees' work place.

Procedures that employees can take to protect themselves from health hazards.

Information regarding actions taken by the employer to provide protection, such as emergency procedures and personal protective equipment, and so on.

29 CFR 1175.1: General Requirements

Compressed gases shall be stored, handled and used in accordance with generally accepted standards.

Cylinders, pressure vessels or containers shall be identified as to the gas contained therein.

Compressed gas cylinders in storage or in service shall be secured to prevent falling or being upset, and shall be protected against tampering by unauthorized persons.

Storage tanks and cylinders located in areas subjected to traffic shall be protected against vehicle damage.

Compressed gas cylinders when not being used shall have their protective caps in place over the valve assembly.

In addition to these sections from 29 *CFR*, you should review the following OSHA regulations in 29 *CFR* concerning the specific topics indicated:

Section 1910.132 -139 on personal protective equipment

Section 1910.38(a) on employer emergency plans and fire prevention plans

For further information on OSHA regulations as they apply to government-owned or government-operated facilities, contact the state department of labor, public employees' safety and health, or a similar organization in your state.

APPENDIX C

PROCESS SAFETY MANAGEMENT

The Clean Air Act Amendments of 1990 mandated, under the OSHA act of 1970 that a chemical process safety standard be set to prevent accidental releases of chemicals that pose a threat to employees. It targets highly hazardous chemicals that have the potential to cause a catastrophic incident both in the workplace and the surrounding community. As a result, "Process Safety Management of Highly Hazardous Substances" (29 *CFR*) covers more than 3 million U.S. workers at nearly 25,000 sites. Sites with 1,500 pounds or more of chlorine in a single process must comply with PSM.

Process safety management is the proactive identification, evaluation, and mitigation or prevention of chemical releases that could occur as a result of failures in process, procedures, or equipment. The major objective of a chemical process safety program is to prevent unwanted releases of hazardous chemicals, especially into locations that could expose employees and others to serious hazards. An effective program requires a systematic approach to evaluating the entire process including design, technology, operational and maintenance activities and procedures, non-routine activities, and training programs. A complete process safety management program includes the following elements:

- Introduction to process safety management
- Employee involvement
- Process safety information
- Process hazards analysis
- Operating procedures
- Employee training
- Requirements applicable to contractors
- Pre-start safety
- Mechanical integrity
- Non-routine work permits
- Managing change
- Incident investigation
- Emergency preparedness
- Compliance audits

To control hazards, employers need to develop the necessary expertise, judgment, and proactive initiative within their workforce to properly implement and maintain an effective process safety management program as envisioned by the OSHA standard.

The various lines of defense that have been incorporated into the design and operation of the process to prevent or mitigate the release of hazardous chemicals need to be periodically evaluated and strengthened to assure their effectiveness at each level.

APPENDIX D

RISK MANAGEMENT PROGRAM

You are covered by the Risk Management Program Rule (RMPR) if you operate a stationary source and have more than 2,500 pounds of chlorine in a process.

The Environmental Protection Agency (EPA) defines stationary sources as buildings, structures, equipment, installations, or substances emitting stationary activities that belong to the same industrial group, which are located on one or more contiguous properties, which are under the control of the same person (or persons under common control) and from which an accidental release may occur (40 *CFR*). The term stationary source does not apply to transportation including storage incident to transportation of any regulated substance, but it does include transportation containers used for storage not incident to transportation and transportation containers connected to equipment at a stationary source for loading or unloading.

This issue is not fully resolved because there is some confusion among several government agencies over regulating and enforcement authority. However, it is the intent of the EPA to apply the RMPR to chlorine tank cars and tank trucks unloading or feeding a process at a facility. In addition, the amount of chlorine in transportation vehicles is an important factor in determining worst-case and alternate scenarios and complying with other parts of the Rule.

The EPA defines process to mean any activity involving a regulated substance, including any use, storage, manufacturing, handling, or on-site movement of such substances, or any combination of these activities. Any group of vessels that are interconnected, or separate vessels that are located in such a way that a regulated substance could be involved in a potential release, is considered a single process. The EPA also says that the owner or operator of a facility must make a reasonable determination as to whether two or more vessels may be involved in the same accident, or whether a release from one vessel may be likely to lead to a release from another.

To our knowledge, neither the Occupational Safety and Health Administration (OSHA) nor the EPA has issued guidelines further refining this definition of process. Each individual site must use the guidelines that are given to determine the number of processes it has. Since the two agencies will not issue additional guidelines, the Chlorine Institute cannot do so either.

If the RMPR applies to your facility, then you will be required to develop a formal risk management program and to register and submit a risk management plan (RMP). The regulations apply to 77 toxic substances (including chlorine, anhydrous ammonia, and sulfur dioxide) and 63 substances that are flammable when certain threshold amounts are met or exceeded in a process. Many of the requirements are similar to Process Safety Management (PSM) rules developed by OSHA (Appendix C), but there are important additional requirements.

The EPA regulations go beyond the PSM rules and require facilities to determine the effect potential workplace chemical accidents may have in the surrounding community. Also, the EPA rules require facilities to register and submit certain data about your risk management program to government agencies and local emergency planning committees (LEPCs), as well as make it available to the general public.

Note: In addition, the list of chemicals covered and the threshold amounts are different for the PSM and RMP. It is technically possible to be covered by the PSM but not by the RMP except under the general duty clause.

Compliance with both the OSHA standard and the EPA's RMP is required by the Clean Air Act Amendments. Operators who incorporate the stipulations of both sets of requirements will be better equipped to meet full compliance while enhancing their relationship with the local community.

The deadline for completing all of the elements in the Risk Management Program and for registering and submitting the RMP is the day you first have a quantity over the threshold in a process.